

AP-2™ ROLLER BEARINGS SERVICE LIMITS
AAR Approval Number 27 (No Field Lubrication)
With Optional Polymer Cage

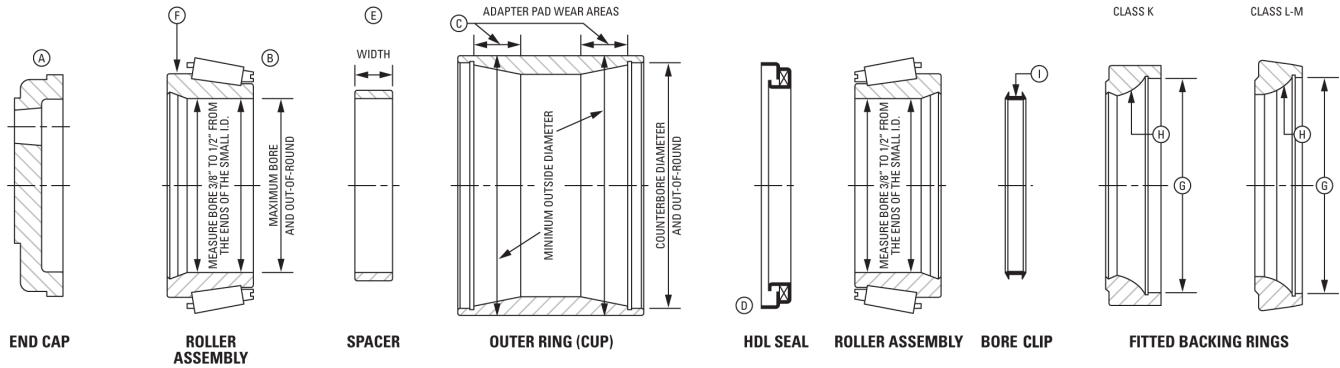

| Diameters are averages | | | | | | | | Amount of grease (ounces) | | |
|------------------------|-----------------|--------------|------------------|-----------------|-----------------|--------------|---------------------|---------------------------|---------------|----------------|
| Class and size | Roller assembly | | Outer ring (cup) | | | | Fitted backing ring | Each roller assembly | Around spacer | Total quantity |
| | Maximum bore | Out-of-round | Minimum OD | Maximum C' bore | Minimum C' bore | Out-of-round | Maximum C' bore | | | |
| L (6 x 8) | 5.6880" | 0.003" | 8.6315" | 8.255" | 8.245" | 0.005" | 7.028" | 2 | 2 | 6 |
| K (6½ x 9) | 6.1880" | 0.003" | 9.8250" | 9.380" | 9.370" | 0.005" | 7.528" | 1 | 8 | 10 |
| G (7x12) | 7.0005 | 0.003" | 10.8750" | 10.423" | 10.420" | 0.005" | 7.996" | 2 | 12 | 16 |

- A. End cap.** Inspect for cracks, breakage, wear or distortion.
- B. Roller assembly – polymer cage inspection.**

WARNING

Failure to observe the following warnings could create risk of death or serious injury.

Never spin a cone assembly.
The rollers may be forcefully expelled, creating a risk of bodily harm.

It is recommended that cone assemblies be returned to Rail Bearing Service for reconditioning. Wash using only water and detergent solutions, not exceeding 190° F. Visually inspect for damage. Only remove rollers from the marked "inspection" pocket (if cage is provided with this feature). Check and ensure proper roller orientation when reapplying these rollers. Separable roller should only be reassembled into the cone from which it was removed. DO NOT mix rollers. DO NOT disassemble or attempt to reapply other rollers. DO NOT stress-relieve cone assemblies and DO NOT plate cone bores of cone assemblies with cages applied. Failure to follow these guidelines could lead to unsatisfactory bearing performance and equipment damage.

- C. Outer ring (cup).** When outer ring shows wear from adapter, the minimum OD is to be measured in the adapter pad wear areas. If the outer ring is distorted in the area of the counterbore, a close visual inspection of the inside and outside surfaces is required. Outer rings that have hairline cracks must be scrapped.
- D. Seal – scrap all used seals.** Seals used in AP-2™ bearing assemblies are a proprietary Timken design. These seals must be replaced only with the appropriate Timken brand seal.

- E. Spacer width – bench lateral.** A spacer must be selected or the spacer may be ground to provide the bearing bench lateral play specified below for the type of lateral measuring equipment used.

| | Power operated | Hand operated |
|---------------|----------------|----------------|
| Classes L-K-G | 0.023"- 0.029" | 0.020"- 0.026" |
| Classes M | 0.025"- 0.030" | 0.022"- 0.027" |

Where close coordination is maintained between the bearing repair facility and the bearing mounting facility, the bearing bench lateral may be set to limits necessary to provide satisfactory mounted bearing lateral.

- F. Cone - fit with seal.** The cone must provide a press fit with the HDL seal.
- G. Backing ring – size (fitted).** Check counterbore.
- H. Backing ring – radius (fitted).** Check bore radius for excessive corrosion. Light pitting and rusting is acceptable. Fillet region must not be galled or pitted. Use fillet gauge as specified in MSRP Section H-2.
- I. Bore clip – scrap all used bore clips.** Bore clips used in AP-2 bearing assemblies are a proprietary Timken design. These clips must be replaced only with appropriate Timken brand clip.

Part numbers – Bearing components

| Class and size | Roller assembly | Outer ring (cup) | Spacer | HDL seal | Ecoturn seal | Fitted backing ring | End cap | Locking plate | Cap screws |
|----------------|-----------------|------------------|------------|----------|--------------|---------------------|---------|---------------|------------|
| L (6 x 8) | NP891226* | NP379567 | NP329204 | K156363 | – | K154512 | K154511 | K80596 | K84354 |
| L (6 x 8) | NP891226F | NP379567 | NP329204 | K156363 | – | K154512 | K154511 | K80596 | K84354 |
| K (6½ x 9) | NP877824* | NP335917 | NP115833 | K153401 | – | K153494 | K154496 | K84324 | K84351 |
| K (6½ x 9) | NP633994F** | NP335917 | NP115833 | K153401 | – | K162227 | K154496 | K84324 | K84351 |
| G (7x12) | NP280681*** | NP949942 | HM136247XA | – | K529701 | K167007 | K167009 | K84701 | K84398 |

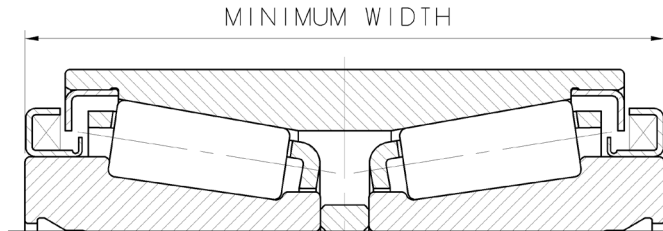

Minimum bearing assembly overall width after reconditioning or remanufacturing, from cone back face to cone back face (not including backing ring and axle end cap), must be within the following dimensions:

| Minimum Width | |
|---------------|---------------|
| Bearing Class | Minimum Width |
| L (6 x 9) | 6.386 inches |
| K (6½ x 9) | 7.102 inches |
| G (7x12) | 8.450 inches |

* Polymer cage can be retrofitted at reconditioning.

** This assembly uses bore clip K162204 for attachment of backing ring to the cone. See note I above.

***This Assembly was assembled with a polymer cage. A polymer cage can be used at reconditioning.

NOTE: Every reasonable effort has been made to ensure the accuracy of the information contained in this writing, but no liability is accepted for errors, omissions or for any other reason.

For additional information, contact your Timken sales representative at 1-800-964-2626 or 1-800-368-4401, or visit www.timken.com/rail.

TIMKEN

The Timken team applies their know-how to improve the reliability and performance of machinery in diverse markets worldwide. The company designs, makes and markets high-performance mechanical components, including bearings, belts, brakes, clutches, chain, couplings, gears and related mechanical power transmission products and services.

Stronger. By Design.

www.timken.com