

## Proper Lubrication Procedures for Wheel Ends

**Proper lubrication carries away heat, reduces friction and prevents corrosion – promoting peak performance and longer bearing and application life.**

In storage and shipping, Timken bearings are protected with a preservative coating that is compatible with most lubricants, however you must properly lubricate the bearing upon installation.

Maintaining proper lubrication starts with daily inspections of the tractor and trailer. Service is needed when there are:

- leaking wheel seals
- lube-stained tire rims
- damaged hub caps
- missing vent plugs
- metallic flakes suspended in the lubricant

Clean and inspect the wheel end components, removing all contaminants and lubricant residue. Replace any questionable parts and never re-use seals.

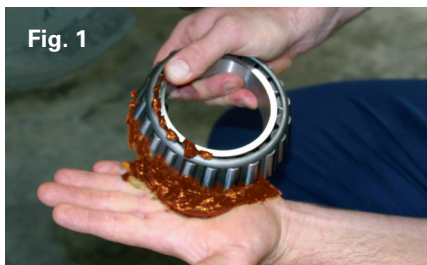

Fig. 1

### Grease Fill Procedures

Pack grease lubrication into the bearing between the rollers and cage (Fig. 1). Force grease from the large end to the small end to ensure proper distribution. You can use a mechanical grease packer (Fig. 2). Excess grease should be smeared on the outside of the rollers. Ample space is essential in the housing to allow room for excess grease to be thrown from the bearing.



Fig. 2

It is equally important to retain the grease around the bearing. For traditional greases (NLGI Nos. 1 and 2), pump a ring of grease into the entire circumference of the wheel hub and coat the hub cap inner wall. The housing should only be half full of grease. Too much grease causes churning and higher temperatures.

### Semi-Fluid (NLGI 00) Greases

Semi-fluid grease must be used with a vented hub cap. It cannot be packed around the bearing as it will slump. Pump this grease into the wheel hub to the bearing cup (outer race) small inside diameter level at the “3 o'clock” and “9 o'clock” levels.

### Oil Fill

Clean the hub and spindle seal seat surfaces. Lubricate the inner and outer wheel bearing cones (inner races) with clean lubricant of the same type used in the hub assembly. Install the inner bearing and the hub on the spindle without damaging spindle threads or seals. Slide the outer inner race into place and adjust the bearings per the manufacturer’s recommendation.

For non-drive wheel ends, attach the appropriate hub cap. Slowly fill the wheel end through the hub cap fill port. Allow the oil to seep through the outer bearing and fill the hub cavity to the fill line (Fig. 3).



Visit [timken.com/techseries](http://timken.com/techseries) to enroll in free technical training.

Get more TechTips online at [www.timken.com/techtips](http://www.timken.com/techtips)

Fig. 3

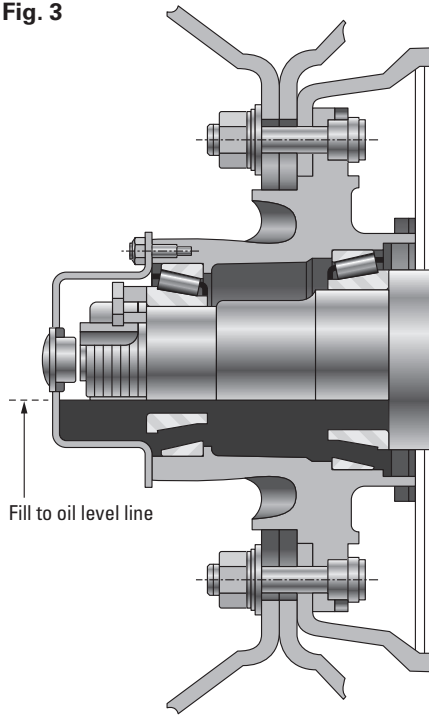

For drive axles, oil is supplied directly to the wheel ends at assembly and through the axle tube during operation. To achieve the final fill level, raise each end of the drive axle a minimum of eight inches above the other wheel end (Fig. 4). Re-check the main sump for the proper fill level and top off the lubricant level, if required. The oil fill level is always to the bottom of the fill plug in the axle reservoir. If unable to tilt the axle, add lubricant to the hub via a fill plug or by adding lubricant to the hub cavity.

Fig. 4

**With axle on level surfaces fill housing with oil to bottom of plug**

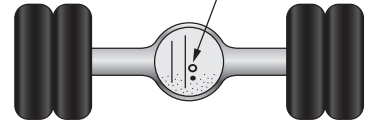

**Tilt housing side to side, one minute per side, then, recheck oil level in axle**

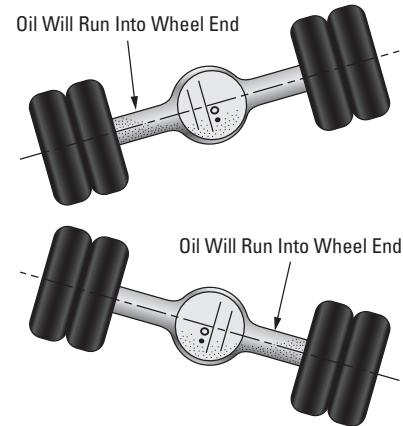

**WARNING**

**Failure to observe the following warnings could create a risk of death or serious injury.**

- Never spin a bearing with compressed air. The components may be forcefully expelled. Proper maintenance and handling practices are critical. Always follow installation instructions and maintain proper lubrication.
- A bearing/component should not be put into service if its shelf life has been exceeded.

**CAUTION**

**Failure to follow these cautions may result in property damage**

- Use of improper bearing fits may cause damage to equipment.
- Do not use damaged bearings.

*TechTips is not intended to substitute for the specific recommendations of your equipment suppliers.*

*Every reasonable effort has been made to ensure the accuracy of the information contained in this writing, but no liability is accepted for errors, omissions or for any other reason.*



The Timken team applies their know-how to improve the reliability and performance of machinery in diverse markets worldwide. The company designs, makes and markets high-performance mechanical components, including bearings, gears, belts, chain and related mechanical power transmission products and services.

[www.timken.com/aftermarket](http://www.timken.com/aftermarket)

Stronger. **Commitment.** Stronger. **Value.** Stronger. **Worldwide.** Stronger. **Together.** | Stronger. **By Design.**