

Ball Bearing Installation

Below are the steps detailing proper installation of ball bearings.

Internal Clearance

In the manufacture of ball bearings, standard practice indicates assembling the rings and balls with a specified internal clearance. This characteristic proves necessary to provide pre-engineered clearance to compensate for the tight fit effects of press fitting the bearing rings on shafts or housings at installation. Internal clearances compensate for thermal expansion

of bearings, shafts and housings or for a contact angle in the bearing after installation. Radial clearance used to create a contact angle is typically used in angular contact ball bearings. Radial measurement is accepted as the more significant characteristic because it is more directly related to shaft and housing fits. Plus, the American Bearing Manufacturers Association (ABMA) prescribes this method.

Proper Installation Procedures

Exert slow, even force against the rings when installing a bearing. When installing a bearing tight fit on a shaft, the pressure should be applied against the inner ring. When installing a bearing tight fit in a housing you should apply pressure against the outer ring. Below are three different guides for installing ball bearings.

Proper Shaft Mounting

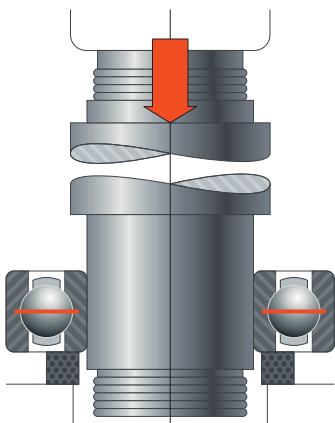

Proper Housing Mounting – Rotating Housing and Loose Shaft

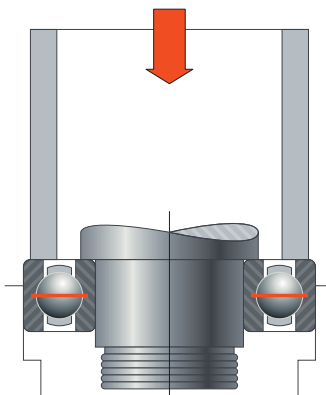

Proper Simultaneous Housing/ Shaft Mounting

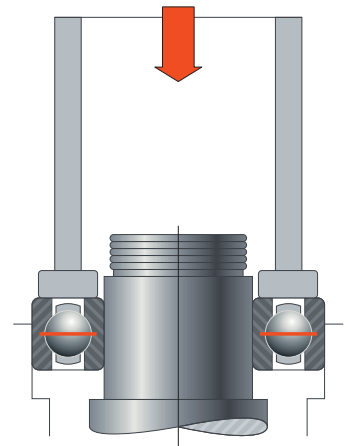



Visit timken.com/techseries to enroll in free technical training.

Get more TechTips online at www.timken.com/techtips

Proper Shaft Installation

Support the bearing's inner ring as the shaft is pressed into the bearing.

Proper Housing Installation – Rotating Housing and Loose Shaft

Press through the outer ring to overcome the tight fit between the outer ring and the housing bore. In this scenario, the shaft does not rotate and fits loose in the inner ring, while the outer ring is tight and rotates.

Proper Simultaneous Housing/Shaft Installation

Press through both rings simultaneously to overcome the tight fit on the shaft and/or housing. In this scenario, the shaft is already in place. Make sure the bearings on the other end of the shaft are properly supported, not damaged and that there is no contact with the bearing cage. Any bent bearing cage is unusable.

A Timken® Conrad deep-groove ball bearing is a standard single-row, deep-groove bearing. It also is referred to as a radial ball bearing. This type of Timken ball bearing is capable of handling radial and axial loads. A wide variety of sizes are available in extra-light to heavy series. Various shield and seal configurations help protect internal bearing components and retain lubricants.

The various types of damage that may occur in ball bearings are basically the same as damage that may occur in other anti-friction bearings, including cylindrical, spherical, needle and tapered designs.

WARNING
Failure to observe the following warnings could create a risk of death or serious injury.

Do not attempt to disassemble and reassemble unitized wheel end hubs and bearing assemblies. Improper reassembly could lead to failure.

Proper maintenance and handling practices are critical. Always follow installation instructions and maintain proper lubrication.

Tensile stresses can be very high in tightly fitted bearing components. Attempting to remove such components by cutting the cone (inner race) may result in a sudden shattering of the component causing fragments of metal to be forcefully expelled. Always use properly guarded presses or bearing pullers to remove bearings from shafts, and always use suitable personal protective equipment, including safety glasses.

CAUTION
Failure to follow these cautions may result in property damage.

The products cataloged are application specific. Any use in applications other than those intended could lead to equipment failure or to reduced equipment life.

Use of improper bearing fits may cause damage to equipment.

Do not use damaged bearings. The use of a damaged bearing can result in equipment damage.

TechTips is not intended to substitute for the specific recommendations of your equipment suppliers. Every reasonable effort has been made to ensure the accuracy of the information contained in this writing, but no liability is accepted for errors, omissions or for any other reason.



The Timken team applies their know-how to improve the reliability and performance of machinery in diverse markets worldwide. The company designs, makes and markets high-performance mechanical components, including bearings, gears, belts, chain and related mechanical power transmission products and services.

www.timken.com/aftermarket

Stronger. **Commitment.** Stronger. **Value.** Stronger. **Worldwide.** Stronger. **Together.** | Stronger. **By Design.**