

AP™ BEARINGS SERVICE LIMITS

Diesel Locomotives

Steel/Polymer Cage with HDL™/EcoTurn® Seal

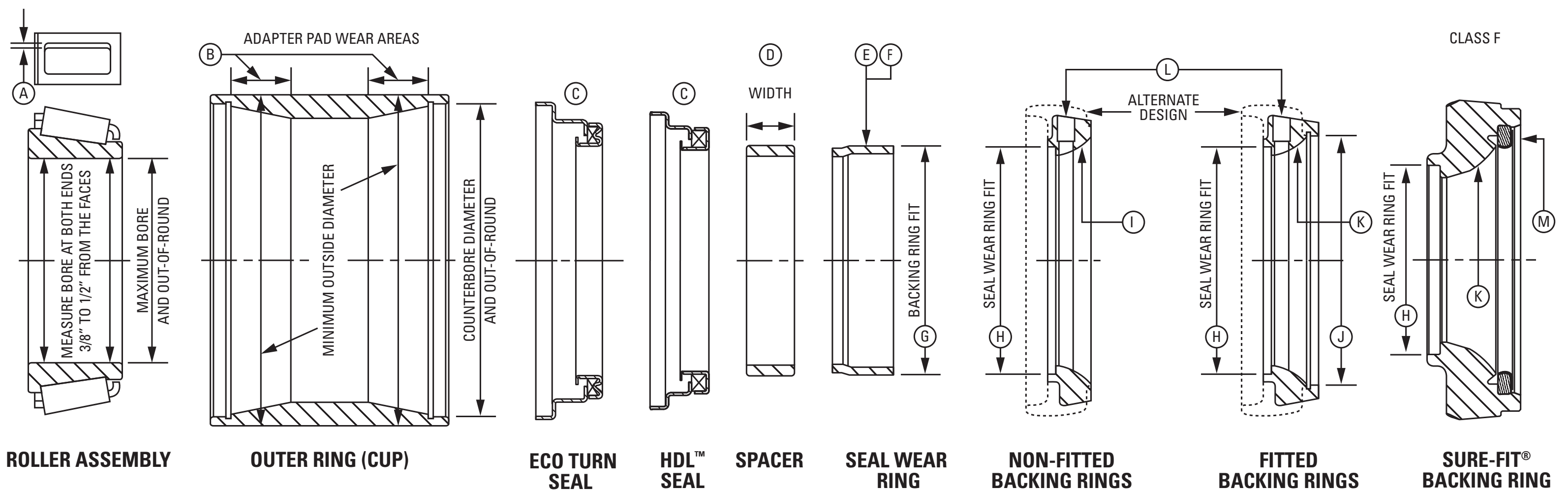

Class and Size	Diameters are Averages								Amount of Grease		
	Roller Assembly			Outer Ring (Cup)				Backing Ring	Each Roller Assembly	Around Spacer	Total Quantity
	Inboard Max. Bore	Outboard Max. Bore	Out-Of-Round	Minimum O.D.	Maximum C'bore	Minimum C'bore	Out-Of-Round	Maximum C'bore	oz.	oz.	oz.
F (6½ x 12)	6.1880	6.1885	0.003	9.9250	9.380	9.3700	0.005	7.528	6	6	18
G (7 x 12)	7.0005	7.0010	0.003	10.8630	10.280	10.2700	0.005	7.998	8	6	22
GG (6¾)	6.8755	6.8760	0.003	11.8730	11.1915	11.1825	0.005	7.869	8	12	28

A. Roller assembly – cage inspection.



WARNING
Failure to observe the following warnings could create risk of death or serious injury.

Never spin a cone assembly.
The rollers may be forcefully expelled, creating a risk of bodily harm. Proper maintenance and handling practices are critical. Always follow installation instructions and maintain proper lubrication.

Do not install on the inboard side (adjacent to the backing ring) of any bearing assembly, any Timken Axle Saver™ Seal Wear Rings P/N K151590, P/N K153392, or P/N K153391 with date code before 08 03. Installation at this position may result in galling of the axle when the bearing is pressed onto the journal, which can cause fracture of the axle in service.

Steel cage inspection

Place roller assembly on back face (large diameter face) when checking clearances. If the roller pocket of the cage is worn to the extent that a 0.060 in. feeler gage can be inserted between the roller and the cage bridge, the roller assembly should not be returned to service.

Polymer cage inspection

It is recommended that cone assemblies be returned to Timken for reconditioning. Wash using only water and detergent solutions, not

exceeding 190° F. Visually inspect for damage. Only remove rollers from the marked "inspection" pocket (if cage is provided with this feature). Check and ensure proper roller orientation when reapplying these rollers. Separable roller should only be reassembled into the cone from which it was removed. DO NOT mix rollers. DO NOT disassemble or attempt to reapply other rollers. DO NOT stress relieve cone assemblies and DO NOT plate cone bores of cone assemblies with cages applied. Failure to follow these guidelines could lead to unsatisfactory bearing performance and equipment damage.

B. Outer ring (cup). When outer ring shows wear from adapter, the minimum O.D. is to be measured in the adapter pad wear areas. If the outer ring is distorted in the area of the counterbore, a close visual inspection of the inside and outside surfaces is required. Outer rings that have hairline cracks must be scrapped.

C. Seal – scrap used seals. Do not mix seal types.

D. Spacer width – bench lateral. A spacer must be selected or the spacer may be ground to provide the bearing bench lateral play specified below for the type of lateral measuring equipment used:

	Power operated	Hand operated
Classes F-G	0.023 in.-0.029 in.	0.020 in.-0.026 in.
Class GG	0.023 in.-0.027 in.	0.020 in.-0.024 in.

Where close coordination is maintained between the bearing repair facility and the bearing mounting facility, the bearing bench lateral may be set to limits necessary to provide satisfactory mounted bearing lateral.

E. Seal wear ring – fit with seal. The seal wear ring must provide a press fit with the seal.

F. Seal wear ring – outside surface. If the outside surface of the seal wear ring is scratched or cracked or if the lip contact path has worn to a depth of 0.005 in. (0.010 in. on diameter), the seal wear ring must be scrapped.

G. Seal wear ring – fit in backing ring. The seal wear ring must have a tight fit in the backing ring counterbore.

H. Backing ring – fit on the seal wear ring. The counterbore of the backing ring must have a tight fit on the seal wear ring. AAR manual permits salvage of backing rings with oversize counterbores, reference AAR MSRP Section H-II, Roller Bearing Manual.

I. Backing ring inspection (non-fitted). Backing rings bent or distorted, and or with excessive corrosion must be scrapped. Inspect the backing radius in accordance to AAR MSRP Section H-II, Roller Bearing Manual.

J. Backing ring – size (fitted). Check counterbore.

K. Backing ring inspection (fitted). Backing rings bent or distorted, and or with excessive corrosion must be scrapped. Inspect the backing radius in accordance to AAR MSRP Section H-II, Roller Bearing Manual.

L. Vent fitting. Backing ring with vent must be handled in accordance to AAR MSRP Section H-II, Roller Bearing Manual requirements.

M. Sure-Fit® backing ring - size (fitted). See Sure-Fit assembly service sheet (order number 10479) for additional safety information.

NOTE: Contact your Timken representative for information on bearing parts that are not shown.

Part Numbers – Bearing Components

Class and Size	Roller Assembly (Steel Cage)*	Roller Assembly (Polymer Cage)	Outer Ring (Cup)	Spacer	HDL™ Seal	EcoTurn® Seal	Seal Wear Ring	Seal Wear Ring (Without Holes)	Non-Fitted Backing Ring				Fitted Backing Ring				Sure-Fit®
									With Shroud - Vented	Without Shroud - Vented	With Shroud - No Vent	Without Shroud - No Vent	With Shroud - Vented	Without Shroud - Vented	With Shroud - No Vent	Without Shroud - No Vent	
F (6½ x 12)	HM133444	HM133444F	HM133416XD	HM133444XA	K147750	K165474	K85509	K151590	K85516	K125696	K504080	–	K529701	K125685	K151303	K524466	**
G (7 x 12)	HM136948	HM136948F	HM136916XD	HM136948XA	K150189	K926664	K147767	K153391	–	–	–	–	K147766	K153497	K151304	K150037	–
GG (6¾)	H337844	H337844F	H337816XD	H337844XA	K150188	–	K524662	K153522	–	–	–	–	–	K524465	–	K153496	–

*Polymer cage can be retrofitted at reconditioning.

Replacements for individual backing rings are available upon request.

**See Sure-Fit assembly service sheet (order number 10479) for additional safety information.

NOTE: Every reasonable effort has been made to ensure the accuracy of the information contained in this writing, but no liability is accepted for errors, omissions or for any other reason.

Visit www.timken.com/markets/rail for additional information.

The Timken team applies their know-how to improve the reliability and performance of machinery in diverse markets worldwide. The company designs, makes and markets bearings, gear drives, automated lubrication systems, belts, brakes, clutches, chain, couplings, linear motion products and related industrial motion rebuild and repair services.

Stronger. By Design.

www.timken.com