

# AP™ BEARINGS SERVICE LIMITS

## Passenger Cars Steel/Polymer Cage with NT Seal

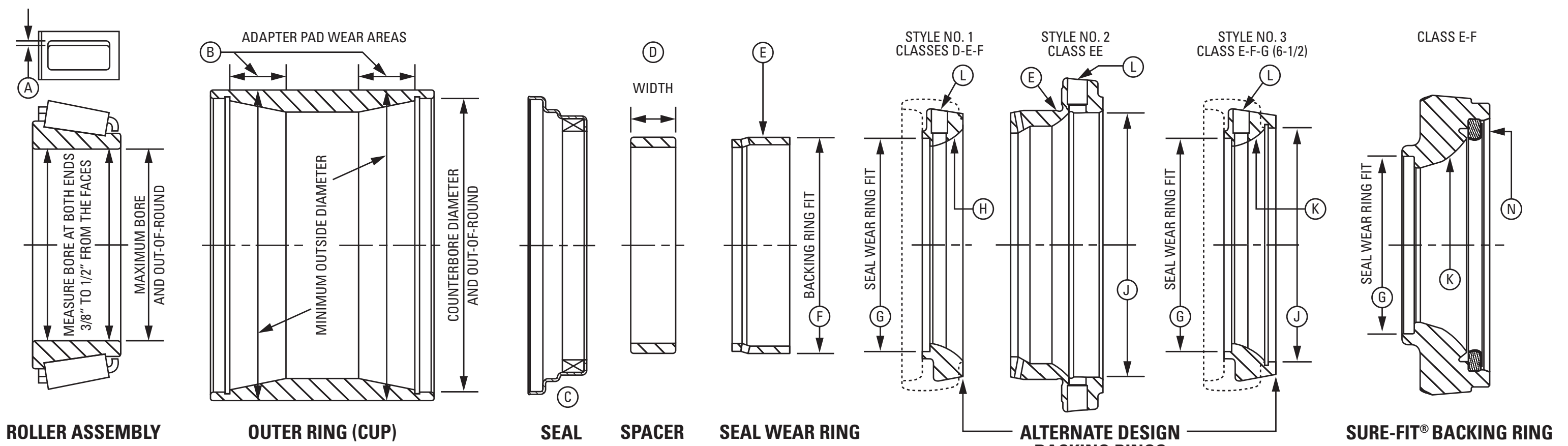

Class and Size	Diameters are Averages							Amount of Grease		
	Roller Assembly		Outer Ring (Cup)				Backing Ring	Each Roller Assembly	Around Spacer	Total Quantity
	+Maximum Bore	Out-of-Round	Minimum O.D.	Maximum C'bore	Minimum C'bore	Out-of-Round	Maximum C'bore	oz.	oz.	oz.
D (5½ x 10)	5.1880	0.003	8.1750	7.7550	7.7450	0.005	—	4	4	12
D - Short Cup	5.1880	0.003	8.2527	7.7550	7.7450	0.005	—	4	4	12
E (6 x 11)	5.6880	0.003	8.6750	8.2550	8.2450	0.005	7.0300	4	6	14
E - Short Cup	5.6880	0.003	8.6464	8.2550	8.2450	0.005	—	4	6	14
EE (5½)	5.5005	0.003	10.8630	10.2790	10.2700	0.005	6.7000	9	9	27
EE (6)	6.0005	0.003	10.8630	10.2790	10.2700	0.005	7.2470	9	9	27
F (6½ x 12)	6.1880	0.003	9.9250	9.3800	9.3700	0.005	7.5300	6	10	22
F - Short Cup	6.1880	0.003	9.8275	9.3800	9.3700	0.005	—	6	10	22
G (6½)	6.5005	0.003	10.8630	10.2800	10.2700	0.005	7.9030	8	10	26
G (7 x 12)	7.0005	0.003	10.8630	10.2800	10.2700	0.005	7.9980	8	10	26

+Applies to inboard position and plated cones only. Outboard cone bores may be up to 0.0005 in. larger.

### A. Roller assembly – cage inspection.

**WARNING**

*Failure to observe the following warnings could create risk of death or serious injury.*

Never spin a cone assembly. The rollers may be forcefully expelled, creating a risk of bodily harm. Proper maintenance and handling practices are critical. Always follow installation instructions and maintain proper lubrication.

Do not install on the inboard side (adjacent to the backing ring) of any bearing assembly, any Timken Axle Saver™ Seal Wear Rings P/N K151590, P/N K153392, or P/N K153391 with date code before 08 03. Installation at this position may result in galling of the axle when the bearing is pressed onto the journal, which can cause fracture of the axle in service.

### Steel cage inspection

Place roller assembly on back face (large diameter face) when checking clearances. If the roller pocket of the cage is worn to the extent that a 0.060 in. feeler gage can be inserted between the roller and the cage bridge, the roller assembly should not be returned to service.

### Polymer cage inspection

It is recommended that cone assemblies be returned to Timken for reconditioning. Wash using only water and detergent solutions, not exceeding 190° F. Visually inspect for damage. Only remove rollers from the marked "inspection" pocket (if cage is provided with this

feature). Check and ensure proper roller orientation when reapplying these rollers. Separable roller should only be reassembled into the cone from which it was removed. DO NOT mix rollers. DO NOT disassemble or attempt to reapply other rollers. DO NOT stress-relieve cone assemblies and DO NOT plate cone bores of cone assemblies with cages applied. Failure to follow these guidelines could lead to unsatisfactory bearing performance and equipment damage.

**B. Outer ring (cup).** When outer ring shows wear from adapter, the minimum O.D. is to be measured in the adapter pad wear areas. If the outer ring is distorted in the area of the counterbore, a close visual inspection of the inside and outside surfaces is required. Outer rings that have hairline cracks must be scrapped.

**C. Seal – scrap used seals.** Do not mix seal types.

**D. Spacer width – bench lateral.** A spacer must be selected or the spacer may be ground to provide the bearing bench lateral play specified below for type of lateral measuring equipment used:

	Power operated	Hand operated
Classes D-E	0.023 in.-0.029 in.	0.020 in.-0.026 in.
Classes F-G	0.027 in.-0.031 in.	0.024 in.-0.028 in.
Class EE	0.021 in.-0.025 in.	0.018 in.-0.022 in.

Where close coordination is maintained between the bearing repair facility and the bearing mounting facility, the bearing bench lateral may be set to limits necessary to provide satisfactory mounted bearing lateral.

**E. Seal wear ring – outside surface.** If the outside surface of the seal wear ring is scratched or cracked or if the lip contact path has worn to a depth

of 0.005 in. (0.010 in. on diameter), the seal wear ring (or backing ring on Class EE bearing size) must be scrapped.

**F. Seal wear ring – fit in backing ring.** The seal wear ring must have a tight fit in the backing ring counterbore (styles 1, 3, and Sure-Fit®).

**G. Backing ring – fit on the seal wear ring.** The counterbore of the backing ring (styles 1, 3, and Sure-Fit) must have a tight fit on the seal wear ring. AAR manual permits salvage of backing rings with oversize counterbores, reference AAR MSRP Section H-II, Roller Bearing Manual.

**H. Backing ring inspection (non-fitted style 1).** Backing rings bent or distorted, and/or with excessive corrosion must be scrapped. Inspect the backing radius in accordance to AAR MSRP Section H-II, Roller Bearing Manual.

**J. Backing ring - size (fitted styles 2 and 3).** Check counterbore.

**K. Backing ring inspection (fitted).** Backing rings bent or distorted, and/or with excessive corrosion must be scrapped. Inspect the backing radius in accordance to AAR MSRP Section H-II, Roller Bearing Manual.

**L. Backing ring.** Backing ring with vent must be handled in accordance to AAR MSRP Section H-II, Roller Bearing Manual requirements.

**M. Vent fittings – when used.** Check the vent fitting to see that it is not clogged, hardened or damaged. Hardened or damaged vent fittings must be replaced.

**N. Sure-Fit backing ring – size (fitted).** See [Sure-Fit assembly service sheet](#) (order number 10479) for additional information.

**NOTE:** Contact your Timken representative for information on bearing parts that are not shown.

### Part Numbers – Bearing Components

Class and Size	Roller Assembly (Steel Cage)	Roller Assembly (Polymer Cage)	Outer Ring (Cup)	Spacer	Seal	Seal Wear Ring (With Holes)	Seal Wear Ring (Without Holes)	Non-Fitted Backing Ring*				Fitted Backing Ring*				Sure-Fit®
								With Shroud - Vented	Without Shroud - Vented	With Shroud - No Vent	Without Shroud - No Vent	With Shroud - Vented	Without Shroud - Vented	With Shroud - No Vent	Without Shroud - No Vent	
D (5½ x 10)	HM127446**	HM127446F	HM127415XD	HM127446XA	K86860	K85507	K157631	K85525	K127205	K153511	K150048	—	—	—	—	
D - Short Cup	HM127446**	HM127446F	HM127417XD	HM127446XB	K86860	K85507	K153503	—	—	—	—	—	—	—	—	
E (6 x 11)	HM129848**	HM129848F	HM129814XD	HM129848XA	K86861	K85508	K153392	K85095	K320054	—	—	K529704	K127206	K150049	K150050	
E - Short Cup	HM129848**	HM129848F	HM129813XD	NP329204	K86861	K85508	K125697	—	—	—	—	—	—	—	—	
EE (5½)	H432640	—	H432614XD	H432640XA	K83082	K522358	—	—	—	—	—	—	K522359	—	—	
EE (6)	H432649	—	H432614XD	H432649XA	K83082	K83081	—	—	—	—	—	—	K83088	—	—	
F (6½ x 12)	HM133444**	HM133444F	HM133416XD	HM133444XA	K85520	K85509	K151590	K85516	—	K504080	—	K529701	K125685	K151303	K524466	
F - Short Cup	HM133444**	HM133444F	HM133413XD	NP115833	K85520	K85509	K151590	—	—	—	—	—	—	—	—	
G (6½)	HM136940**	HM136940F	HM136916XD	HM136940XA	K96501	K96537	K154507	—	—	—	—	K100638	K96539	—	K115426	
G (7 x 12)	HM136948**	HM136948F	HM136916XD	HM136948XA	K96501	K147767	K153391	—	—	—	—	K147766	K153497	K151304	K150037	

\*Backing ring styles interchangeable.

\*\*Polymer cage can be retrofitted at reconditioning.

\*\*\*See Sure-Fit assembly service sheet (order number 10479) for additional safety information.

Replacements for individual backing rings are available upon request.

**NOTE:** Every reasonable effort has been made to ensure the accuracy of the information contained in this writing, but no liability is accepted for errors, omissions or for any other reason.

Visit [www.timken.com/markets/rail](http://www.timken.com/markets/rail) for additional information.

The Timken team applies their know-how to improve the reliability and performance of machinery in diverse markets worldwide. The company designs, makes and markets bearings, gear drives, automated lubrication systems, belts, brakes, clutches, chain, couplings, linear motion products and related industrial motion rebuild and repair services.

**Stronger. By Design.**

[www.timken.com](http://www.timken.com)