

AP™ BEARINGS SERVICE LIMITS

AAR Approval Numbers 1 and 1A

Steel/Polymer Cage with NT Seal (No Field Lubrication)

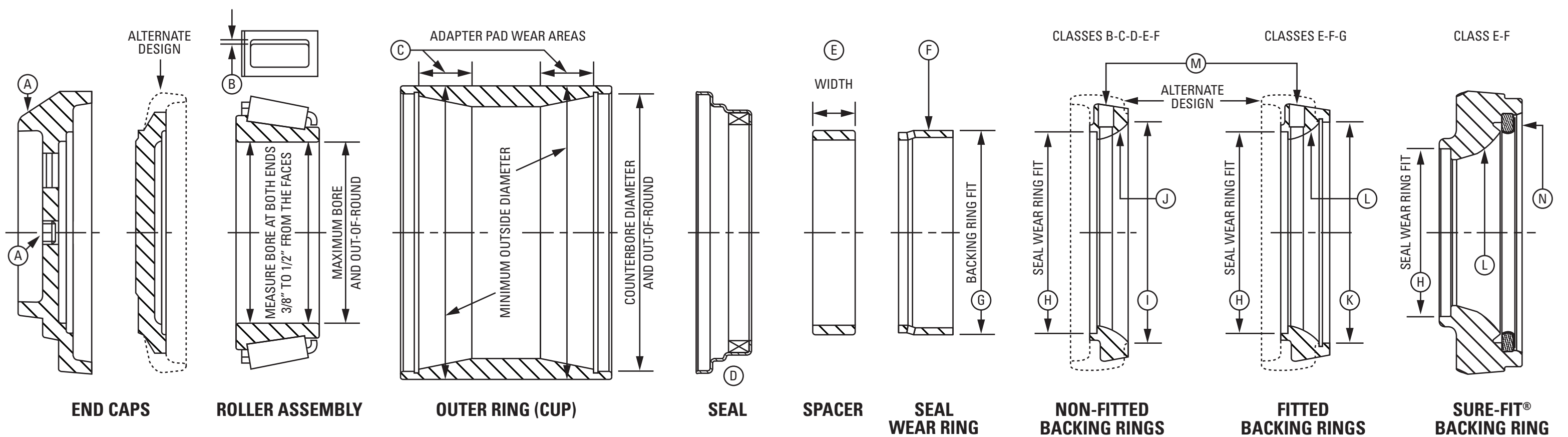

Class and Size	Diameters are Averages						Amount of Grease				
	Roller Assembly		Outer Ring				Fitted Backing Ring	Non-Fitted Backing Ring	Each Roller Assembly	Around Spacer	Total Quantity
	+Maximum Bore	Out-of-Round	Minimum O.D.	Maximum C'bore	Minimum C'bore	Out-of-Round	Maximum C'bore	Max. Break-Out Dia.			
in.	in.	in.	in.	in.	in.	in.	in.	oz.	oz.	oz.	
B (4¼ x 8)	4.0010	0.003	6.4900	6.067	6.0600	0.005	-	5.035	2	4	8
C (5 x 9)	4.6885	0.003	7.6775	7.192	7.1850	0.005	-	5.910	3	6	12
D (5½ x 10)	5.1880	0.003	8.1750	7.755	7.7450	0.005	-	6.410	4	4	12
E (6 x 11)	5.6880	0.003	8.6750	8.255	8.2450	0.005	7.028	7.035	4	6	14
F (6½ x 12)	6.1880	0.003	9.9250	9.380	9.3700	0.005	7.528	7.535	6	10	22
G (7 x 12)	7.0005	0.003	10.8630	10.280	10.2700	0.005	7.998	-	8	10	26

+Applies to inboard position and plated cones only. Outboard cone bores may be up to 0.0005 in. larger.

A. End cap. Inspect for cracks, breakage, wear or distortion. If end cap is equipped with lubricant fitting, remove and replace with a non-removable plug (K523685 or K523653 as appropriate).

B. Roller assembly – cage inspection.



WARNING
Failure to observe the following warnings could create risk of death or serious injury.

Never spin a cone assembly.
The rollers may be forcefully expelled, creating a risk of bodily harm.

Proper maintenance and handling practices are critical. Always follow installation instructions and maintain proper lubrication.

Do not install on the inboard side (adjacent to the backing ring) of any bearing assembly, any Timken Axle Saver™ Seal Wear Rings P/N K151590, P/N K153392, or P/N K153391 with date code before 08 03. Installation at this position may result in galling of the axle when the bearing is pressed onto the journal, which can cause fracture of the axle in service.

Steel cage inspection

Place roller assembly on back face (large diameter face) when checking clearances. If the roller pocket of the cage is worn to the extent that a 0.060 in. feeler gage can be inserted between the roller and the cage bridge, the roller assembly should not be returned to service.

Polymer cage inspection

It is recommended that cone assemblies be returned to Timken for reconditioning. Wash using only water and detergent solutions, not exceeding 190° F. Visually inspect for damage. Only remove rollers from the marked "inspection" pocket (if cage is provided with this feature). Check and ensure proper roller orientation when reapplying these rollers. Separable roller should only be reassembled into the cone from which it was removed. DO NOT mix rollers. DO NOT disassemble or attempt to reapply other rollers. DO NOT stress relieve cone assemblies and DO NOT plate cone bores of cone assemblies with cages applied. Failure to follow these guidelines could lead to unsatisfactory bearing performance and equipment damage.

C. Outer ring (cup). When outer ring shows wear from adapter, the minimum O.D. is to be measured in the adapter pad wear areas. If the outer ring is distorted in the area of the counterbore, a close visual inspection of the inside and outside surfaces is required. Outer rings that have hairline cracks must be scrapped.

D. Seal – scrap used seals. Do not mix seal types.

E. Spacer width – bench lateral. A spacer must be selected or the spacer may be ground to provide the bearing bench lateral play specified below for the type of lateral measuring equipment used.

	Power operated	Hand operated
Classes B-C	0.021 in.-0.027 in.	0.018 in.-0.024 in.
Classes D-E-F-G	0.023 in.-0.029 in.	0.020 in.-0.026 in.

Where close coordination is maintained between the bearing repair facility and the bearing mounting facility, the bearing bench lateral may be set to limits necessary to provide satisfactory mounted bearing lateral.

F. Seal wear ring – outside surface. If the outside surface of the seal wear ring is scratched or cracked, or if the lip contact path has worn to a depth of 0.005 in. (0.010 in. on diameter), the seal wear ring must be scrapped.

G. Seal wear ring – fit in backing ring. The seal wear ring must have a tight fit in the backing ring counterbore.

H. Backing ring – fit on the seal wear ring. The counterbore of the backing ring must have a tight fit on the seal wear ring. AAR manual permits salvage of backing rings with oversize counterbores, reference AAR MSRP Section H-II, Roller Bearing Manual.

I. Backing ring – size (non-fitted). Check break-out diameter.

J. Backing ring inspection (non-fitted). Backing rings bent or distorted, and or with excessive corrosion must be scrapped. Inspect the backing radius in accordance to AAR MSRP Section H-II, Roller Bearing Manual.

K. Backing ring – size (fitted). Check counterbore.

L. Backing ring inspection (fitted). Backing rings bent or distorted, and or with excessive corrosion must be scrapped. Inspect the backing radius in accordance to AAR MSRP Section H-II, Roller Bearing Manual.

M. Vent fitting. Backing ring with vent must be handled in accordance to AAR MSRP Section H-II, Roller Bearing Manual requirements.

N. Sure-Fit® backing ring – size (fitted). See [Sure-Fit assembly service sheet](#) (order number 10479) for additional safety information.

Part Numbers – Bearing Components

Class and Size	Roller Assembly (Steel Cage)	Roller Assembly (Polymer Cage)	Outer Ring (Cup)	Spacer	Seal	Seal Wear Ring (without holes)	Seal Wear Ring (with holes)	Non-Fitted Backing Ring**				Fitted Backing Ring**				Old Style* End Cap	New Style End Cap*		Locking Plate	Cap Screws	
								With Shroud-Vented	Without Shroud-Vented	With Shroud-No Vent	Without Shroud-No Vent	With Shroud-Vented	Without Shroud-Vented	With Shroud-No Vent	Without Shroud-No Vent		With Shroud	Without Shroud			
B (4¼ x 8)	HM120848	-	HM120817XD	HM120848XA	K86895	-	K86890	K86874	K127203	-	-	-	-	-	K86877	-	K523660	K84326	K53399		
C (5 x 9)	HM124646	-	HM124618XD	HM124646XA	K85600	-	K86002	K85588	K127204	K153512	-	-	-	-	K86003	-	K151315	K84325	K44434		
D (5½ x 10)	HM127446***	HM127446F	HM127415XD	HM127446XA	K86860	K157631	K85507	K85525	K127205	K153511	K150048	-	K524571	-	K85521	-	K523744	K80511	K44434		
E (6 x 11)	HM129848***	HM129848F	HM129814XD	HM129848XA	K86861	K153392	K85508	K85095	K320054	-	-	K529704	K127206	K150049	K150050	****	K85510	K529703	K523746	K80596	K84354
F (6½ x 12)	HM133444***	HM133444F	HM133416XD	HM133444XA	K85520	K151590	K85509	K85516	-	K504080	-	K529701	K125685	K151303	K524466	****	K85517	K529706	K523748	K84324	K84351
G (7 x 12)	HM136948***	HM136948F	HM136916XD	HM136948XA	K96501	K153391	K147767	-	-	-	-	K147766	K153497	K151304	K150037	-	K95199	K147768	K523750	K84701	K84398

*End cap styles interchangeable. Replacements are available upon request.

**Backing ring styles interchangeable. Replacements are available upon request.

*** Polymer cage can be retrofitted at reconditioning.

****See Sure-Fit assembly service sheet (order number 10479) for additional safety information.

AAR Approval No. 1 and 1A bearing parts are interchangeable. Do not use AAR Approval 20 bearing parts in AAR Approval 1 or 1A bearing assemblies except where part numbers are the same or as permitted by AAR Roller Bearing Manual Rule 3.7.2.5.1.

NOTE: Every reasonable effort has been made to ensure the accuracy of the information contained in this writing, but no liability is accepted for errors, omissions or for any other reason.

Visit www.timken.com/markets/rail for additional information.

The Timken team applies their know-how to improve the reliability and performance of machinery in diverse markets worldwide. The company designs, makes and markets bearings, gear drives, automated lubrication systems, belts, brakes, clutches, chain, couplings, linear motion products and related industrial motion rebuild and repair services.

Stronger. By Design.

www.timken.com