

Pre-Adjusted Wheel Ends with Spacers Require Controlled Width Bearings

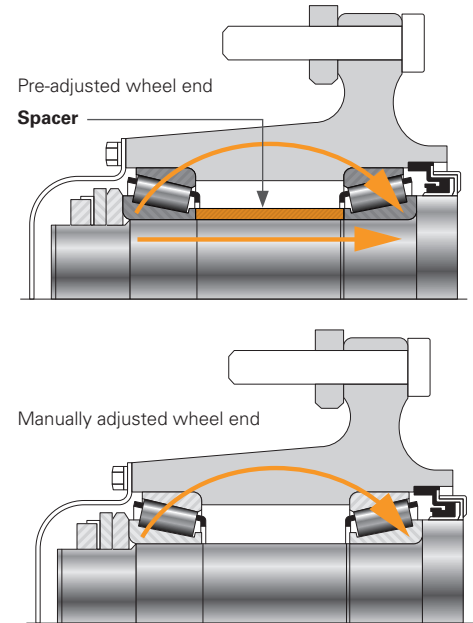

Fig. 1: Comparison of a pre-adjusted wheel end (with spacer) and a manually adjusted wheel end (no spacer)

Pre-adjusted wheel ends (Fig. 1) use a spacer (Fig. 2) and tightly controlled tolerances among the bearings, spacer and hub to create the bearing setting.

When using a spacer, you must use the correct bearings (controlled width) or the bearing setting will be too loose or tight — potentially causing seal leaks, tire wear, hub burn up or wheel separation.

Timken® Set-Right® bearings are controlled width bearings (Fig. 3) with unique NP part numbers (i.e. NP840302) to clearly differentiate them from traditional bearings (i.e. 580) and to help reduce the chance of improper installation. **Set-Right bearings are engineered to help achieve proper bearing setting with spacers.**



Fig. 2: Common types of spacers

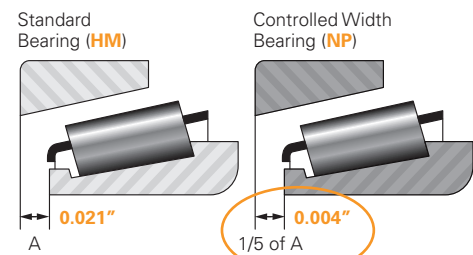

Fig. 3: Comparison of a standard and a controlled width bearing

Skill Level: Intermediate | Special Tools: None



Visit www.timken.com/techseriespro to enroll in free technical training.

WHEEL-END COMPONENT PERFORMANCE

	Tires	Spindles & Wheel Hubs	Seals	Bearings
Endplay	⊘		⊘	Yellow
Bearing Setting	✓	✓	✓	Green
Preload		⊘		Yellow
				Red

Bearing setting too loose = excessive endplay that can lead to seal leakage or tire wear
 Bearing setting too tight = excessive preload that can lead to hub burn up or wheel separation

IMPROVED BEARING LIFE

WARNING: Never use standard bearings with a spacer as they will double the possible setting range.

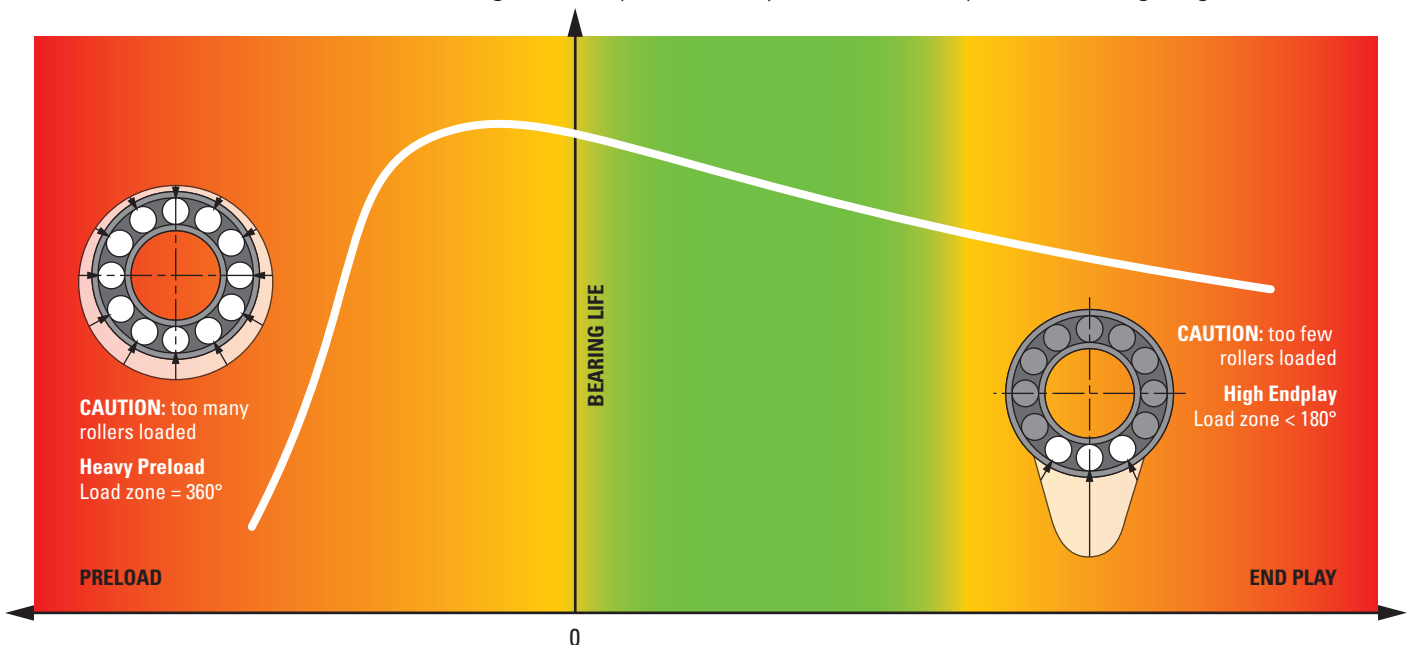

RED SHADED AREAS HAVE A HIGHER LIKELIHOOD OF: Hub burn up, seal leaks, tire wear, wheel separation

WHEEL BEARING PART NUMBERS FOR HUBS WITH AND WITHOUT SPACERS

			SPACER				NO SPACER	
	Position	Type	Reduced Width	Reduced Width Sets	Reduced Width Kits with Both Inner and Outer Bearing and Spacer		Standard P/N	Standard Sets
FF (Steer)	Inner	Bearing	NP899357	Set 427	FFTC1	FF Steer Kit	HM212049	Set 413
		Race	NP026773	Set 427	Set 427	1	HM212011	Set 413
	Outer	Bearing	NP874005	Set 428	Set 428	1	3782	Set 406
		Race	NP435398	Set 428	Spacer 103592	1	3720	Set 406
FL (Steer)	Inner	Bearing	NP294109	Set 445	FLTC1	FL Steer Kit	6461A	Set 423
		Race	NP039695	Set 445	Set 445	1	6420	Set 423
	Outer	Bearing	NP107091	Set 446	Set 446	1	555-S	Set 424
		Race	NP183330	Set 446	Spacer 103807	1	552A	Set 424
R (Drive)	Inner	Bearing	NP034946	Set 429	RDTC1	R Drive Kit	594A	Set 403
		Race	NP363298	Set 429	Set 429	1	592A	Set 403
	Outer	Bearing	NP840302	Set 430	Set 430	1	580	Set 401
		Race	NP053874	Set 430	Spacer 103593	1	572	Set 401
TN (Trailer)	Inner	Bearing	NP965350	Set 431	TNTC1	N Trailer Kit	HM218248	Set 414
		Race	NP503727	Set 431	Set 431	1	HM218210	Set 414
	Outer	Bearing	NP899357	Set 427	Set 427	1	HM212049	Set 413
		Race	NP026773	Set 427	Spacer 104144	1	HM212011	Set 413
TP (Trailer)	Inner/ Outer	Bearing	NP174964	Set 432	TPTC1	P Trailer Kit	HM518445	Set 415
		Race	NP593561	Set 432	Set 432	2	HM518410	Set 415
					Spacer 104412	1		
			Controlled Width Bearings				Standard Bearings	



Visit www.timken.com/techseriespro to enroll in free technical training.

Get more TechTips online at www.timken.com/techtips

CONMET TO TIMKEN WHEEL BEARING INTERCHANGE

PreSet / PreSet Plus Hub Bearing Sets

Application	TIMKEN				Conmet No.	Hyatt Cup / Cone No.
	Set No.	Cup / Cone No.	454 Set No.	454 Cup / Cone No.		
FF Steer Axle / Inner Bearing Cup & Cone	SET427	NP026773 / NP899357	SET603	NP454773 / NP454357	10041905	HM212011 PS / HM212049 PS
FF Steer Axle / Outer Bearing Cup & Cone	SET428	NP435398 / NP874005	SET605	NP454398 / NP454005	10041906	3720 PS / 3782 PS
FL Steer Axle / Inner Bearing Cup & Cone	SET445	NP039695 / NP294109	N/A	N/A	10041925	461A PS / 6420 PS
FL Steer Axle / Outer Bearing Cup & Cone	SET446	NP107091 / NP183330	N/A	N/A	10041926	555S PS / 552A PS
R Drive Axle / Inner Bearing Cup & Cone	SET429	NP363298 / NP034946	SET600	NP454298 / NP454946	10041915	592A PS / 594A PS
R Drive Axle / Outer Bearing Cup & Cone	SET430	NP053874 / NP840302	SET601	NP454874 / NP454302	10041916	572 PS / 580 PS
TN Trailer Axle / Inner Bearing Cup & Cone	SET431	NP503727 / NP965350	SET602	NP454727 / NP454350	10041935	HM218210 PS / HM218248 PS
TN Trailer Axle / Outer Bearing Cup & Cone	SET427	NP026773 / NP899357	SET603	NP454773 / NP454357	10041905	HM212011 PS / HM212049 PS
TP Trailer Axle / Inner & Outer Bearing Cup & Cone	SET432	NP593561 / NP174964	SET604	NP454561 / NP454964	10041945	HM518410 PS / HM518445 PS

WARNING

Failure to observe the following warnings could create a risk of death or serious injury.

Never spin a bearing with compressed air. The components may be forcefully expelled. Proper maintenance and handling practices are critical. Always follow installation instructions and maintain proper lubrication.

A bearing/component should not be put into service if its shelf life has been exceeded.

CAUTION

Failure to follow these cautions may result in property damage

Use of improper bearing fits may cause damage to equipment.

Do not use damaged bearings.

TechTips is not intended to substitute for the specific recommendations of your equipment suppliers.

Every reasonable effort has been made to ensure the accuracy of the information contained in this writing, but no liability is accepted for errors, omissions or for any other reason.

TIMKEN

The Timken team applies their know-how to improve the reliability and performance of machinery in diverse markets worldwide. The company designs, makes and markets bearings, gear drives, automated lubrication systems, belts, brakes, clutches, chain, couplings, linear motion products and related power transmission rebuild and repair services.

Stronger. By Design.

www.timken.com/aftermarket