

AP-2™ BEARINGS SERVICE LIMITS

AAR Approval Number 27 (No Field Lubrication)
With Optional Polymer Cage

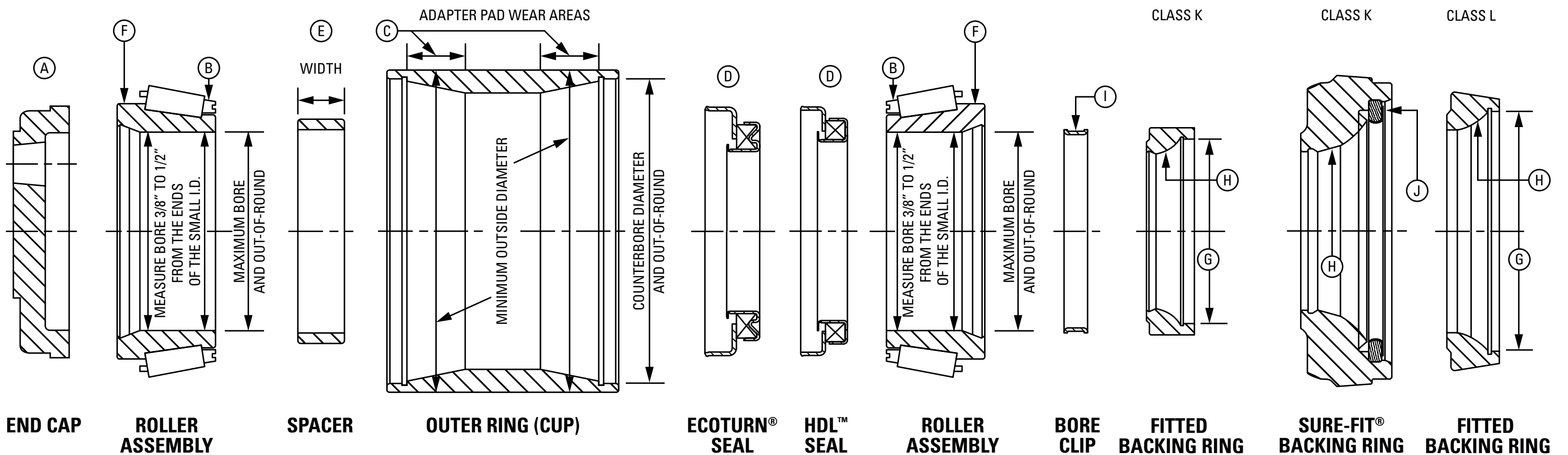

Class and Size	Diameters are Averages							Amount of Grease		
	Roller Assembly		Outer Ring (Cup)				Fitted Backing Ring	Each Roller Assembly	Around Spacer	Total Quantity
	Maximum Bore	Out-of-Round	Minimum O.D.	Maximum C' bore	Minimum C' bore	Out-of-Round	Maximum C' bore	oz.	oz.	oz.
L (6 x 8)	5.6880	0.003	8.6315	8.255	8.245	0.005	7.028	2	2	6
K (6½ x 9)	6.1880	0.003	9.8250	9.380	9.370	0.005	7.528	2	6	10

- A. End cap.** Inspect for cracks, breakage, wear or distortion.
- B. Roller assembly – polymer cage inspection.**

WARNING

Failure to observe the following warnings could create risk of death or serious injury.

Never spin a cone assembly.
The rollers may be forcefully expelled, creating a risk of bodily harm.
Proper maintenance and handling practices are critical. Always follow installation instructions and maintain proper lubrication.

It is recommended that cone assemblies be returned to The Timken Company for reconditioning. Wash using only water and detergent solutions not exceeding 190° F. Visually inspect for damage. Only remove rollers from the marked "inspection" pocket (if cage is provided with this feature). Check and ensure proper roller orientation when reapplying these

rollers. Separable roller should only be reassembled into the cone from which it was removed. DO NOT mix rollers. DO NOT disassemble or attempt to reapply other rollers. DO NOT stress-relieve cone assemblies and DO NOT plate cone bores of cone assemblies with cages applied. Failure to follow these guidelines could lead to unsatisfactory bearing performance and equipment damage.

- C. Outer ring (cup).** When outer ring shows wear from adapter, the minimum O.D. is to be measured in the adapter pad wear areas. If the outer ring is distorted in the area of the counterbore, a close visual inspection of the inside and outside surfaces is required. Outer rings that have hairline cracks must be scrapped.
- D. Seal – scrap all used seals.** Seals used in AP-2™ bearing assemblies are a proprietary Timken design. These seals must be replaced only with the appropriate Timken branded seal. Do not mix seal types.
- E. Spacer width – bench lateral.** A spacer must be selected or the spacer may be ground to provide the bearing bench lateral play specified below for the type of lateral measuring equipment used.

- Power operated**
Classes L-K 0.023 in.-0.029 in.
- Hand operated**
0.020 in.-0.026 in.
- Where close coordination is maintained between the bearing repair facility and the bearing mounting facility, the bearing bench lateral may be set to limits necessary to provide satisfactory mounted bearing lateral.
- F. Cone – fit with seal.** The cone must provide a press fit with the seal.
- G. Backing ring – size (fitted).** Check counterbore.
- H. Backing ring inspection (fitted).** Backing rings bent or distorted, and or with excessive corrosion must be scrapped. Inspect the backing radius in accordance to AAR MSRP Section H-II, Roller Bearing Manual.
- I. Bore clip – scrap all used bore clips.** Bore clips used in AP-2 bearing assemblies are a proprietary Timken design. These clips must be replaced only with appropriate Timken branded clip.
- J. Sure-Fit® backing ring - size (fitted).** See [Sure-Fit assembly service sheet](#) (order number 10479) for additional safety information.

Part Numbers – Bearing Components

Class and Size	Roller Assembly	Outer Ring (Cup)	Spacer	HDL™ Seal	EcoTurn® Seal	Fitted Backing Ring	Sure-Fit® Backing Ring	End Cap	Locking Plate	Cap Screws
L (6 x 8)	NP891226*	NP379567	NP329204	K156363	–	K154512	–	K154511	K80596	K84354
L (6 x 8)	NP891226F	NP379567	NP329204	K156363	–	K154512	–	K154511	K80596	K84354
K (6½ x 9)	NP877824*	NP335917	NP115833	K153401	K163774	K153494	***	K154496	K84324	K84351
K (6½ x 9)	NP633994F**	NP335917	NP115833	K153401	K163774	K162227	***	K154496	K84324	K84351

* Polymer cage can be retrofitted at reconditioning.
** This assembly uses bore clip K162204 for attachment of backing ring to the cone. See letter I on the previous page.
*** See Sure-Fit assembly service sheet (order number 10479) for additional safety information.

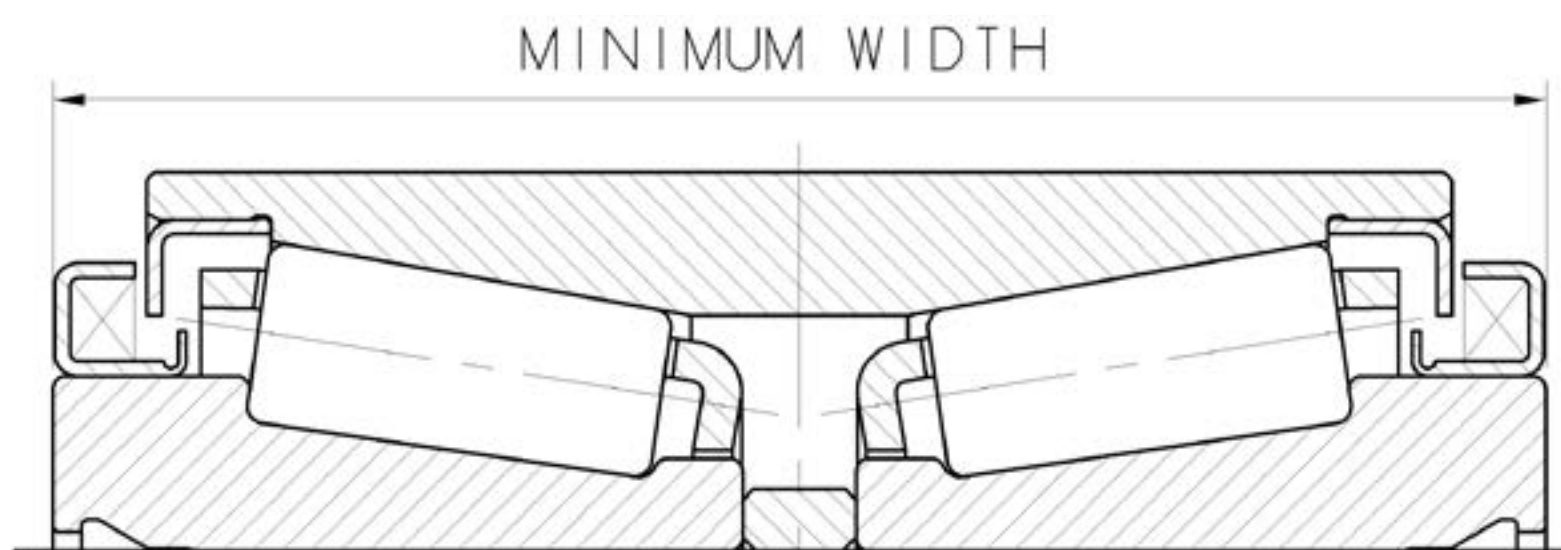

Minimum bearing assembly overall width after reconditioning or remanufacturing, from cone back face to cone back face (not including backing ring and axle end cap), must be within the following dimensions:

Minimum Width	
Bearing Class	Minimum Width
L (6 x 9)	6.386 in.
K (6½ x 9)	7.102 in.

NOTE: Every reasonable effort has been made to ensure the accuracy of the information contained in this writing, but no liability is accepted for errors, omissions or for any other reason.

Visit www.timken.com/markets/rail for additional information.

The Timken team applies their know-how to improve the reliability and performance of machinery in diverse markets worldwide. The company designs, makes and markets bearings, gear drives, automated lubrication systems, belts, brakes, clutches, chain, couplings, linear motion products and related industrial motion rebuild and repair services.

Stronger. By Design.

www.timken.com