

TIMKEN

AP-2™ Bearing

The Timken® AP™ bearing was introduced in 1954 as a replacement for the widely used friction journal bearings. This self-contained, pre-lubricated bearing package quickly became the design of choice for the industry.

Over time, rail operations evolved. The industry was challenged to improve efficiency and productivity and to lower costs. To achieve this, freight-car weights increased, and trains were operated at higher running speeds. Heavier loads caused more wear and tear on equipment, including fretting wear. These factors raised concerns about bearing reliability.

To meet these growing challenges of increased loads, speeds and longer wheel life, Timken developed the AP-2 bearing for freight cars. Today, almost a million Timken AP-2 bearings are in service.

A Better Design

The patented Timken AP-2 design provides for reduced journal axle flexure and less fretting wear. Its compact design incorporates fewer components and reduces bearing weight. In fact, the weight savings per car using AP-2 bearings in place of an AP bearing can reduce the weight of a railcar by several hundred pounds. The AP-2 bearing also offers improved safety and reliability and runs at lower operating temperatures and lower torque than an AP bearing.

When integrated with innovative Timken seal designs and polymer cages, Timken's AP-2 bearing can offer significant energy efficient benefits while providing railroad operators with unparalleled performance.



Timken AP-2™ Bearing

The Bearing of Choice: The AP-2™ Bearing Is Designed To...

Reduce the likelihood of bearing damage due to increased contaminant exclusion.

Reduce bearing set outs by lowering seal operating temperature.

Reduce fuel cost due to low operating torque.

Provide a polymer cage option with enhanced performance benefits in a high vibration rail application.

Evenly distribute lateral force to provide positive clamp to entire bearing stack.

Reduce axle fillet damage by minimizing the potential for water ingress and resulting corrosion.

Reduce component wear rejection. The Timken design provides the shortest distance between the cone face and the dust guard. This design reduces the amount of movement and the resultant wear on the cone back face.

Unitize entire bearing assembly and backing ring to aid in installation procedure.

Decrease potential axle failure. The shorter axle journal design provides a longer and stiffer dust guard, which, in turn, reduces stress at the crucial axle fillet area.

Eliminate axle grooving. By removing the seal wear ring in the Timken design, axle grooving – and the resulting scrapping or expensive repairs of the axle – can be eliminated.

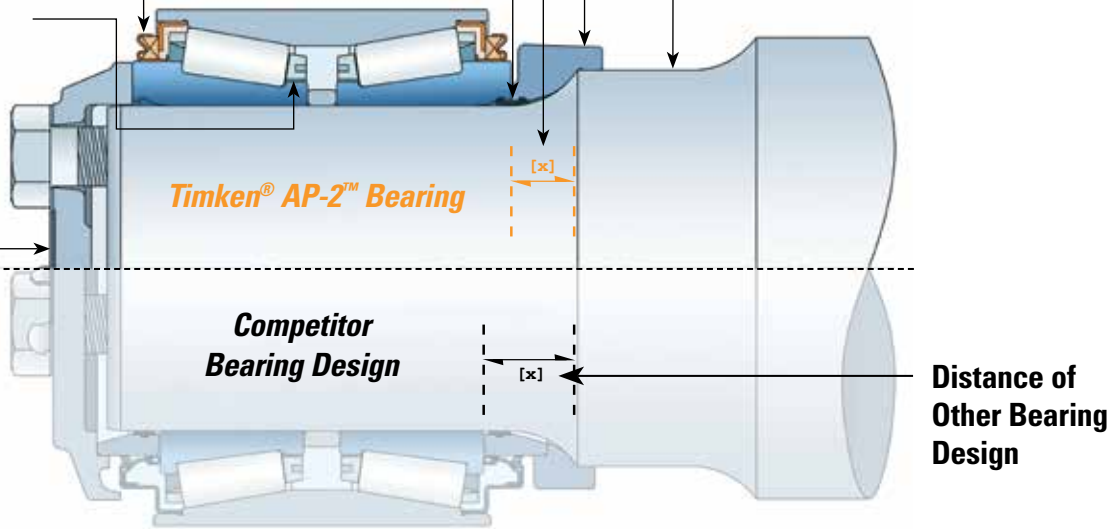

Weight Savings Comparison:

Timken® AP™ Bearing vs. Timken® AP-2™ Bearing

AP-2 Class K – 6½ x 9 in. (165.1 mm x 228.6 mm) for 286,000 lbs. (130,000 kg) Gross Rail Load Cars				
	Bearings (2)	Adapters (2)	Axle	Total
Class F Shrouded	223.5 lbs. (101.4 kg)	70.5 lbs. (32.0 kg)	1175.0 lbs. (533.0 kg)	1469.0 lbs. (666.3 kg)
Class K	178.0 lbs. (80.7 kg)	64.0 lbs. (29.0 kg)	1168.0 lbs. (529.8 kg)	1410.0 lbs. (640.0 kg)
Savings Per Wheelset				59.0 lbs. (26.8 kg)
Savings Per Car				236.0 lbs. (101.7 kg)

TIMKEN

The Timken team applies their know-how to improve the reliability and performance of machinery in diverse markets worldwide. The company designs, makes and markets high-performance mechanical components, including bearings, gears, belts, chain and related mechanical power transmission products and services.