

AP-2™ ROLLER BEARINGS SERVICE LIMITS

AAR Approval Number 27

(No Field Lubrication)

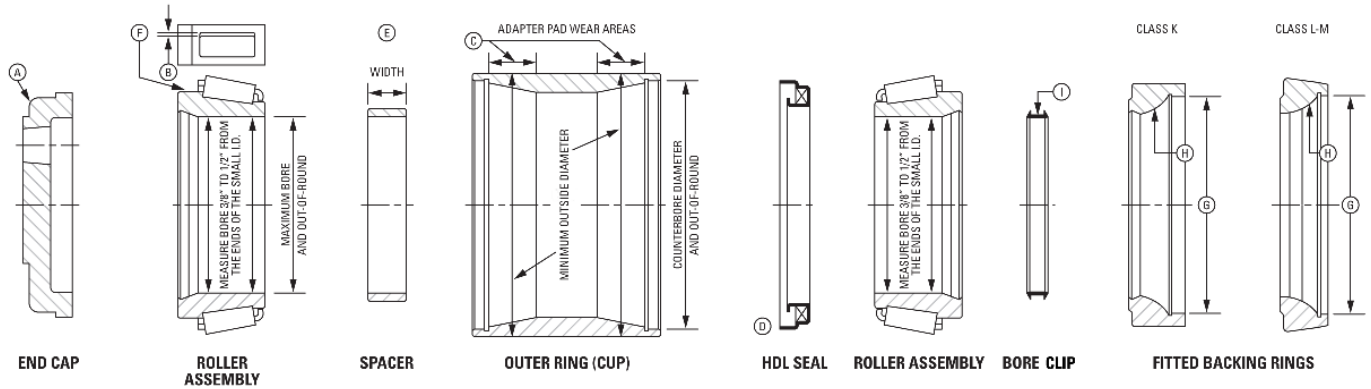

Class and size	Diameters are averages							Amount of grease (ounces)		
	Roller assembly		Outer ring				Fitted backing ring	Each roller assembly	Around spacer	Total quantity
	Maximum bore	Out-of-round	Minimum OD	Maximum C'bore	Minimum C'bore	Out-of-round	Maximum C'bore			
L (6 x 8)	5.6880"	0.003"	8.6315"	8.255"	8.245"	0.005"	7.028"	2	4	8
K (6½ x 9)	6.1880"	0.003"	9.8250"	9.380"	9.370"	0.005"	7.528"	2	6	10
M (7 x 9)	6.5005"	0.003"	10.3630"	9.780"	9.770"	0.005"	7.528"	2	8	12

- A. End cap.** Inspect for cracks, breakage, wear or distortion.
- B. Roller assembly – cage inspection.**

WARNING

Failure to observe the following warnings could create risk of death or serious injury.

Never spin a cone assembly.
The rollers may be forcefully expelled, creating a risk of bodily harm.

Place roller assembly on back face (large diameter face) when checking clearances. If the roller pocket of the cage is worn to the extent that a 0.060" feeler gage can be inserted between the roller and the cage bridge, the roller assembly should not be returned to service.

- C. Outer ring (cup).** When outer ring shows wear from adapter, the minimum OD is to be measured in the adapter pad wear areas. If the outer ring is distorted in the area of the counterbore, a close visual inspection of the inside and outside surfaces is required. Outer rings that have hair line cracks must be scrapped.
- D. Seal – scrap all used seals.** Seals used in AP-2™ bearing assemblies are a proprietary Timken design. These seals must be replaced only with the appropriate Timken brand seal.

- E. Spacer width – bench lateral.** A spacer must be selected or the spacer may be ground to provide the bearing bench lateral play specified below for the type of lateral measuring equipment used.

	Power operated	Hand operated
Classes L-K	0.023"- 0.029"	0.020"- 0.026"
Classes M	0.025"- 0.030"	0.022"- 0.027"

Where close coordination is maintained between the bearing repair facility and the bearing mounting facility, the bearing bench lateral may be set to limits necessary to provide satisfactory mounted bearing lateral.

- F. Cone - fit with seal.** The cone must provide a press fit with the HDL seal.
- G. Backing ring – size (fitted).** Check counterbore.
- H. Backing ring – radius (fitted).** Check bore radius for excessive corrosion. Light pitting and rusting is acceptable. Fillet region must not be galled or pitted. Use fillet gauge as specified in MSRP Section H-2.
- I. Bore clip – scrap all used bore clips.** Bore clips used in AP-2 bearing assemblies are a proprietary Timken design. These clips must be replaced only with appropriate Timken brand clip.

Part numbers – Bearing components

Class and size	Roller assembly	Outer ring (cup)	Spacer	HDL seal	Fitted backing ring	End cap	Locking plate	Cap screws
L (6 x 8)	NP891226**	NP379567	NP329204	K156363	K154512	K154511	K80596	K84354
K (6½ x 9)	NP877824**	NP335917	NP115833	K153401	K153494	K154496	K84324	K84351
K (6½ x 9)	*NP633994**	NP335917	NP115833	K153401	K162227	K154496	K84324	K84351
M (7 x 9)	NP239427	NP540329	NP353018	K154504	K154505	K154506	K84324	K84351

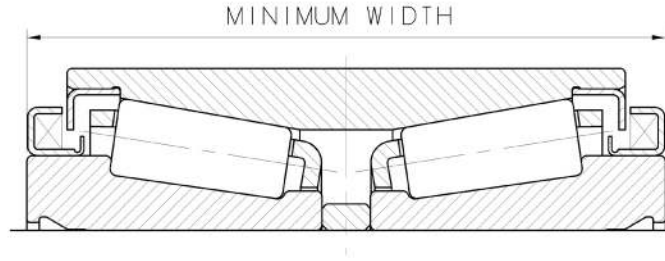

Minimum bearing assembly overall width after reconditioning or remanufacturing, from cone back face to cone back face (not including backing ring and axle end cap), must be within the following dimensions:

Minimum Width	
Bearing Class	Minimum Width
L (6 x 9)	6.386 inches
K (6½ x 9)	7.102 inches
M (7 x 9)	7.328 inches

For additional information on bearings equipped with polymer cages, please reference the specific service limit charts for these bearing assemblies.

* This assembly uses bore clip K162204 for attachment of backing ring to the cone. See note I above.

** Polymer cage can be retrofitted at reconditioning.

NOTE: Every reasonable effort has been made to ensure the accuracy of the information contained in this writing, but no liability is accepted for errors, omissions or for any other reason.

For additional information, contact your Timken sales representative at 1-800-964-2626 or 1-800-368-4401, or visit www.timken.com/rail.

TIMKEN

The Timken team applies their know-how to improve the reliability and performance of machinery in diverse markets worldwide. The company designs, makes and markets high-performance mechanical components, including bearings, belts, chain, gears and related mechanical power transmission products and services.

Stronger. By Design.

www.timken.com