

TIMKEN

Friction Management Solutions for Industrial Gear Drives

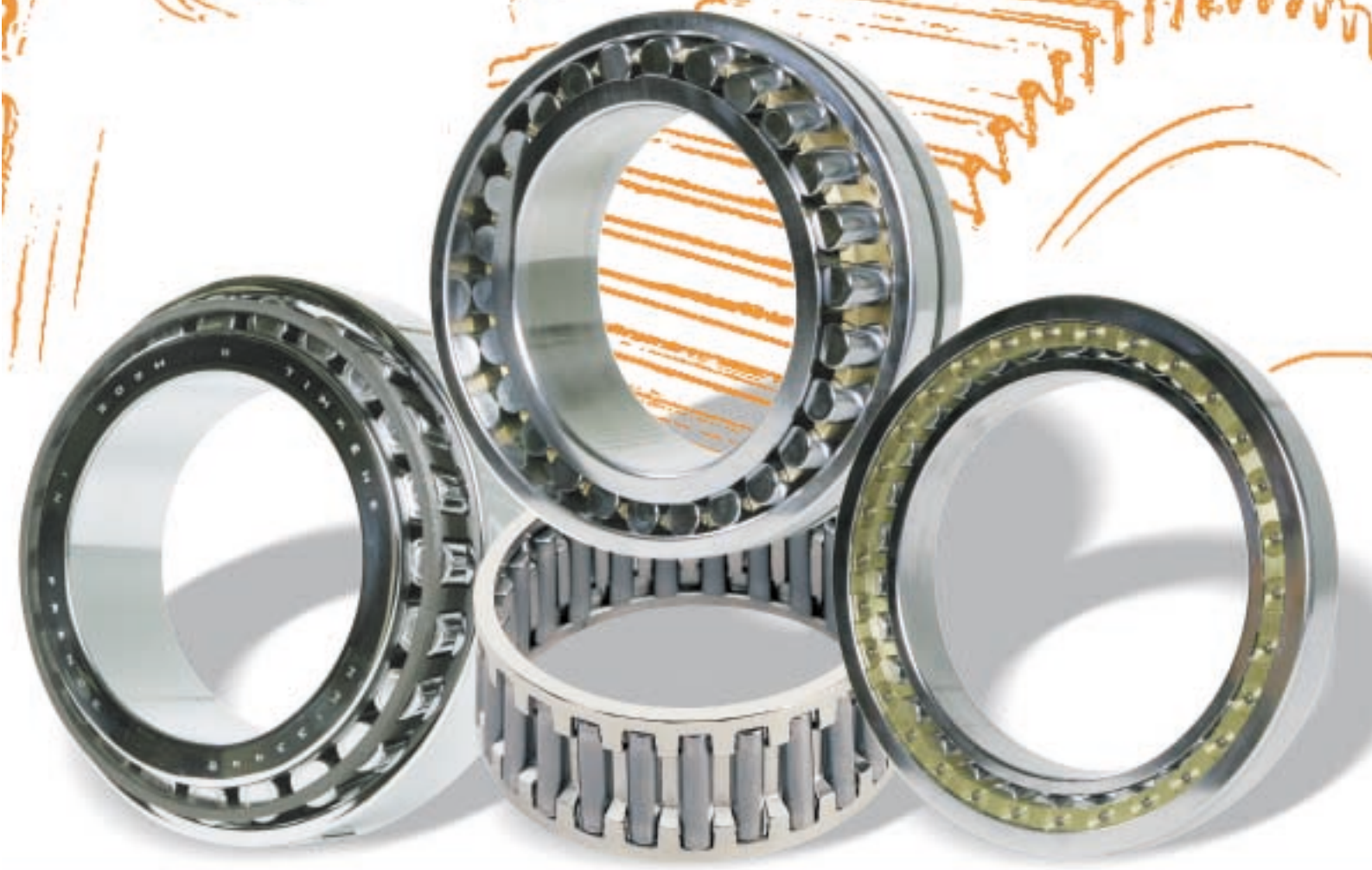

Due to clean steel technology and advanced profiles and finishes, the smaller bearing can carry the same load and has the same life expectancy as the larger bearing carried 40 years ago. This is a reduction of 50% in size and 76% in weight.



Power transmission technology is a motor of progress in a fast changing world. Better know-how, advanced materials science and higher computing power are driving improvements in all stages of gear drive development and production and leading to significantly smaller gear drive sizes.

Timken® roller bearings are contributing to this evolution. Advances in metallurgy, internal geometry and lubrication are significantly improving bearing life and operational reliability. Timken engineers are constantly working to enhance power density and performance in gear drive applications.

Two major changes have strengthened our ability to serve global markets:

- A significantly expanded product line of metric size bearings.
- A comprehensive bearing portfolio that includes tapered, spherical, cylindrical, needle, ball, radial ball and thrust bearings for both original equipment manufacturers and the replacement market.

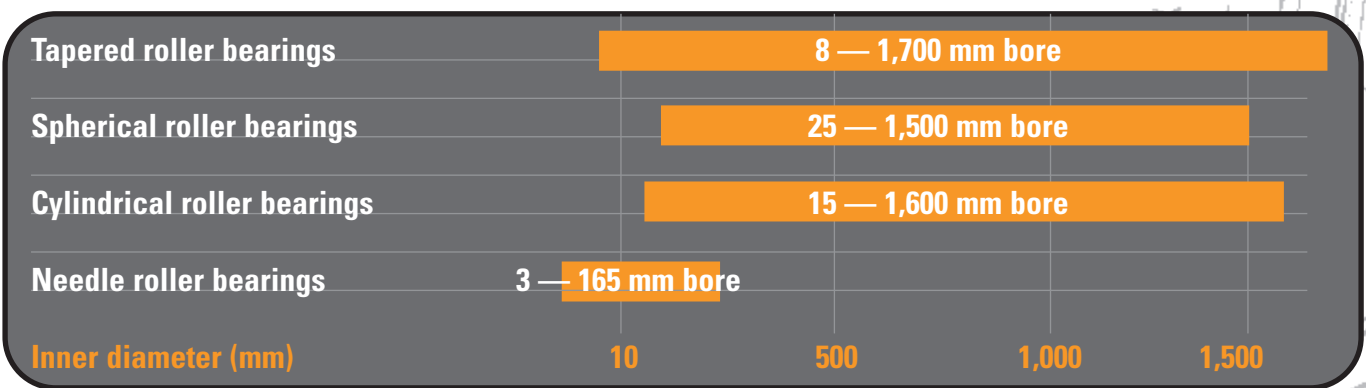

Timken is a leading international manufacturer of highly engineered bearings, alloy and specialty steels and a provider of related products and services. The company employs 26,000 people worldwide in operations in 29 countries. More than 80 plants and 120 sales offices, design centers and distribution centers make sure that Timken meets the global needs of customers.

Rigorous worldwide quality standards ensure product quality and interchangeability, regardless which Timken facility produces the bearings. The fact that Timken produces per year more than 30,000 different metric- and inch-based antifriction bearings, enables the company to serve virtually every major industry. Innovation speed, customer centricity and a deep understanding of industry needs build the strong foundation on which Timken performance is based.

ADVANTAGES

- WORLDWIDE AVAILABILITY OF PRODUCTS
- HIGH QUALITY
- LATEST BEARING TECHNOLOGY
- COMPREHENSIVE PRODUCT RANGE
- DECADES OF GEAR DRIVE INDUSTRY EXPERIENCE
- GLOBAL APPLICATION ENGINEERING SUPPORT

A COMPLETE RANGE OF BEARINGS AND COMPLEMENTARY SERVICES HELP THE GEAR DRIVE INDUSTRY TO MEET EVER-INCREASING REQUIREMENTS IN PRODUCT RELIABILITY AND PRODUCTION EFFICIENCY.

COMPLETE TORQUE RANGE

Nearly all bearing types can be used in power transmission engineering. The choice depends on the gear drive design and gear tooth system. From small precision planetary to large-scale cement gearboxes, Timken has reliable and innovative products for the complete torque range.

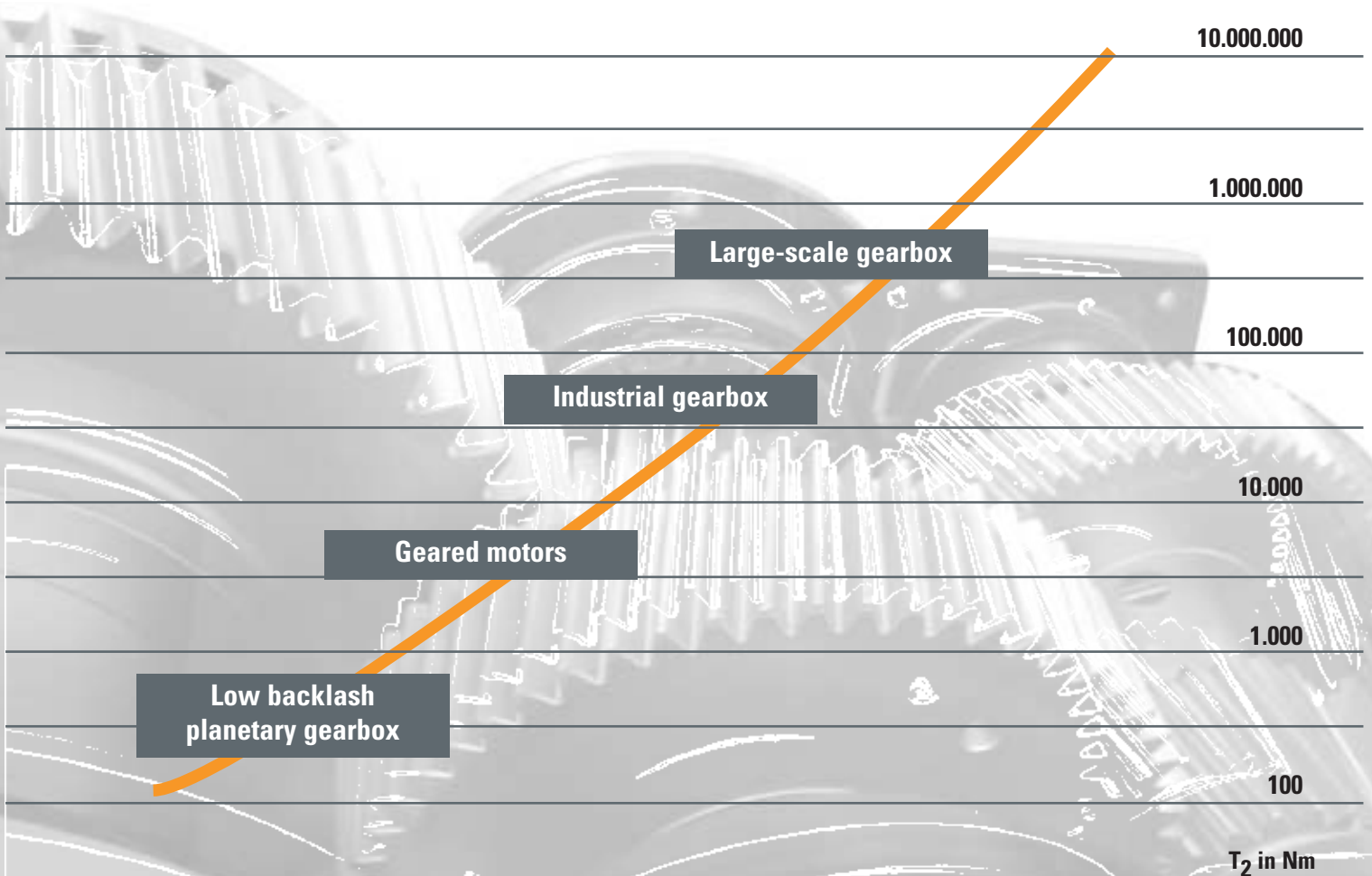

HELICAL / HELICAL-BEVEL / BEVEL GEARBOXES

Today's standard gear unit programs are designed as modular construction systems enabling short delivery times. They are universally applicable for horizontal and vertical installation and available in a various sizes.

The latest technological advances in the gear drive industry are applied to gear shape, profile, cutting and finishing then combined with advanced metallurgy and tribology to produce gear units with higher power density or smaller housings that achieve the same output torque. All Timken® bearings are designed to meet or exceed the latest performance standards of the global gear drive industry.

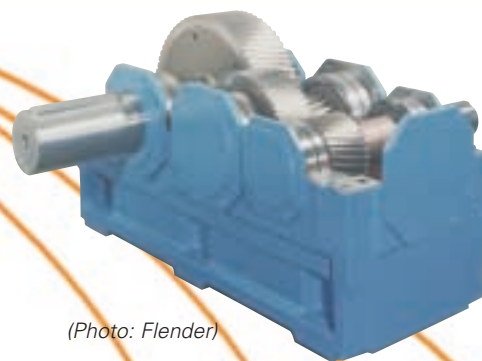

(Photo: Flender)

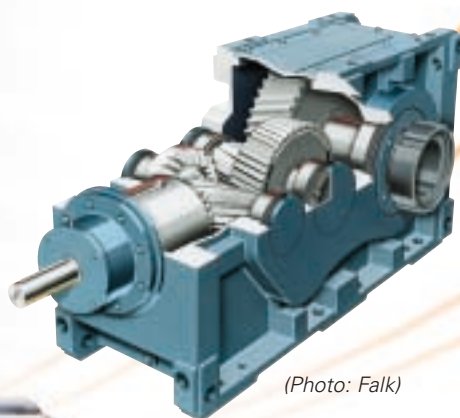

(Photo: Falk)

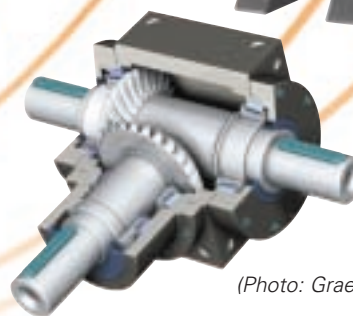

(Photo: Graessner)



**Size range:
8 mm – 1,700 mm bore
(5/16" – 67")**

TAPERED ROLLER BEARINGS

Timken is the world's largest manufacturer of tapered roller bearings. A wide size range of standard and special designs are available in both metric and inch dimensions. The single row bearing is the most widely used type. Double row and flanged-single row bearings complete our standard range for industrial gear drive applications.

These bearings play a fundamental role in ensuring cost-efficient operation resulting from minimum downtime and maximum service life. They can withstand high radial and axial loads in any combination and are adjustable to meet optimum application-specific settings that can minimize axial movement of gear shafts and improve gear alignment. These criteria are crucial to reliability, noise reduction and system life in light alloy and downsized housings.

PLANETARY GEARBOXES

Planetary, or epicyclic gearboxes are the most compact drive solution for transmitting motion. The name was created due to the rotational resemblance to the solar system.

The planetary arrangement incorporates a central sun gear, an outer annulus with internal gear teeth and a set of 3-5 planet gears which engage with both the sun and the outer annulus.

Planetary gearboxes combine high torque with minimum dimensions. Furthermore they offer low weight and high efficiency and are common in 1-3 stage units or combined with helical or bevel stages to achieve highest possible ratios and mounting flexibility.

They are optionally available in shaft mounted, foot mounted or flange mounted designs making them universally applicable in many industrial branches.

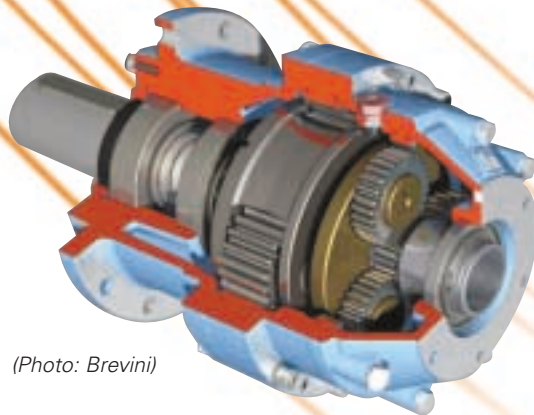

(Photo: Brevini)

CYLINDRICAL ROLLER BEARINGS

Timken cylindrical roller bearings are designed to manage heavy radial loads through expertly designed critical dimensions, such as roller and raceway diameter and contact geometry. Timken makes a variety of sizes and designs in both metric and inch dimensions.

The most common type is the single-row cylindrical bearing, but Timken also offers various configurations of two-row bearings as well as the large bore bearings which are commonly used in the gear drive industry. These bearings can also be customized for use in large-scale gear drive applications.



Size range:
15mm – 1,600 mm bore
(0.59" – 56")

GEARED MOTORS

Geared motors are one of the most popular gear drive designs. They are distinguished by modularity, compact design, excellent cost-performance ratio and a variety of application orientated mounting positions.

Geared motors in paraxial design are popular as helical, parallel shaft and planetary geared motors. They are characterized by 1-3 stage designs and high efficiencies. While the helical geared motor is the standard paraxial design, the parallel shaft helical geared motor is ideal for restricted mounting positions.

Right-angle geared motors are available as helical-bevel and helical-worm geared motors. While the helical-bevel geared motors are an energy efficient solution, the helical-worm geared motor features high ratios in one stage with extremely low-noise operation.

Helical-bevel geared motor

Worm geared motor

Helical geared motor

Shaft mounted geared motor



Size range:
25 mm – 1,500 mm bore
(0.9843" – 59.0551")

SPHERICAL ROLLER BEARINGS

Spherical roller bearings consist of two rows of rollers which gives them the capacity to carry high radial loads. Their matching spherical surfaces of inner ring, outer ring and rollers enable the bearings to compensate for modest misalignment between a rotating shaft and the bearing housing.

The Timken range of spherical roller bearings consists of different series available for various application combinations of loads and speeds.

LOW BACKLASH PLANETARY GEAR DRIVES

The requirements for low backlash gear drives are very demanding. Extreme angular accelerations combined with high torsional stiffness and high accuracy in positioning and revolution speed require state-of-the-art technology. The best options for applications such as this are low backlash planetary and planetary-bevel gearboxes in conjunction with dynamic synchronous servo motors.

In contrast to standard gear drives, low backlash gear drives are charged with explicitly greater radial forces and require high power density. These conditions make great demands on the bearings.

Timken supports precision gear drive manufacturers by providing high quality bearings backed up by application engineering know-how. We help our customers to reduce friction torque, especially on the fast running input shaft.

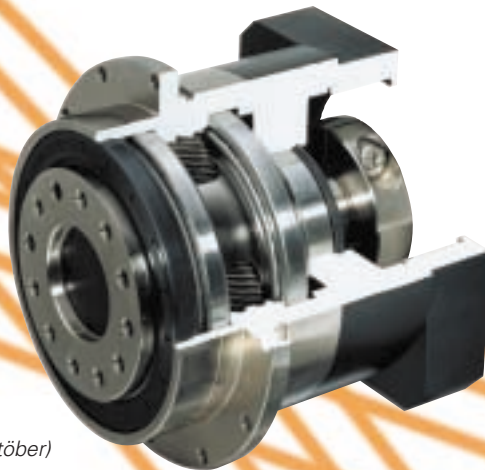

(Photo: Stöber)

THIN SECTION TAPERED ROLLER BEARINGS

For low thickness/diameter ratios in a given application, thin section tapered roller bearings meet the challenge. High power density planetary gear drives are a typical application for thin section tapered roller bearings.

NEEDLE ROLLER BEARINGS

Whether supplied as individual components or as unit assemblies, Timken products offer maximum load and speed capability within the smallest possible design envelope. When a rolling bearing must support very high dynamic, static or even shock loads within a restricted mounting space, the needle roller bearing can offer best results.

Our compact, efficient and long-life designs allow gear drive manufacturers to increase power density and extend product life while minimizing lubrication demands and reducing overall package size. Timken's metric and inch series needle roller and cage radial assemblies are available in a variety of sizes in both standard and non-standard designs.

Size range:
35 mm - 325 mm bore
(1.3775" - 12.75")



Size range:
3 mm - 165 mm bore
(0.375" - 6.5")

WORM GEARBOXES

Worm gearboxes pose a classical drive technology solution and cover a torque range from small geared motors to medium sized industrial gearboxes.

The shock resistant, vibration absorbing and low-noise tooth system allows high ratios in only one stage. With a smaller number of parts compared to multiple stage gear units, worm gearboxes are price competitive and offer high operational reliability.

The carrying capacity of the tooth system has been increasing due to the use of modern lubrication technology that reduces efficiency differences between worm gears and helical-bevel gearboxes.

Standard worm gearboxes are used in nearly every industry sector while customized versions are found in applications such as elevator and escalator drives.

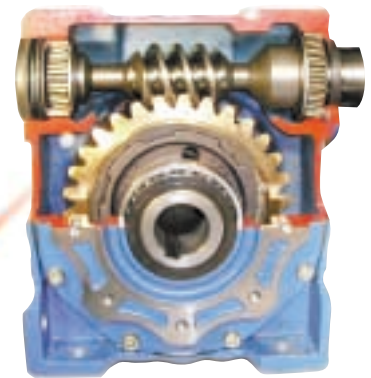
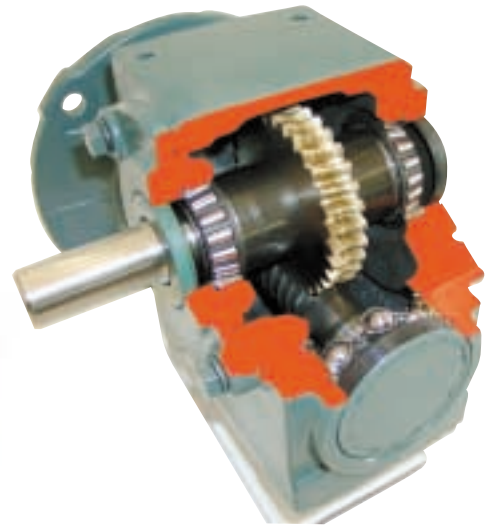

(Photo: Motovario)



CONDITION MONITORING

The Timken product portfolio also offers ways to monitor and improve overall gear drive system performance. The condition monitoring products include portable instruments, continuous monitoring devices and online systems. This equipment evaluates bearing condition, lubrication quality and machine vibration, and can identify potential system issues before failure occurs.

A comprehensive condition monitoring program can:

- Increase productivity and equipment uptime
- Reduce capital expenditure by maximizing machinery life
- Reduce repair costs through planned maintenance
- Improve workplace safety

LARGE-SCALE GEARBOXES



*Timken tapered roller bearing
up to 1,700 mm inner diameter*



*Timken spherical roller bearing
up to 1,600 mm inner diameter*



*Timken cylindrical roller bearing
up to 1,500 mm inner diameter*

Large-scale gear drives are designed for applications where high torque must be generated at low speed. A large scale helical gear drive is characterized by a minimum one meter distance between the input and output shafts. Large-scale planetary gear drives feature a hollow wheel with a diameter of at least one meter.

Typical application examples are equipment for cement production, as well as the steel, marine and wind energy industries. Large-scale gear units are subject to strict quality standards. Critical importance is placed on smooth operation and absolute reliability. This is achieved by hardened, ground and extremely precise gear wheels and by fitting the shafts with highest quality bearings.

TWO ROW BEARINGS WITH DOUBLE-OUTER RACE (TDO)

TDO bearings are applied to heavy duty gear drives and a variety of other applications. These bearings can be used at fixed or floating positions. They have a double outer race and two single inner races, and are usually supplied complete with an inner race spacer as a pre-set assembly.



Size range:
9.525 mm – 2,085 mm bore
(0.3750" – 82.0866")

PACKAGES FOR PLANETARY GEARBOXES

A common observation among designers of epicyclical gearing systems is that the bearing rating of each planetary idler represents one of the major limitations to increasing the power rating of a gearbox. Another well-known limitation is the inherent misalignment imposed inside the gear meshes and bearings by the torsional wind up of the planetary carrier. To accommodate these conditions, designers have often resorted to using systems having three planetary idlers with larger aspect ratios and thinner rims than desired. This conventional approach does not usually balance the bearing and gear capacities, so maximum power density is rarely achieved.

The Timken Company now offers two new integrated bearing solutions having increased bearing capacity and improved performance features that are ready to take the power density of epicyclical gear systems to an all new level. These bearing solutions are labeled Planet-Pac for conventionally designed 1 and 2 piece straddle carriers; and the Integrated Flex Pin Bearing for single walled planetary carriers.

PLANET-PAC FOR ONE AND TWO PIECE STRADDLE CARRIERS

A conventional planetary idler will often use bearings having outer races pressed into the gear and inner races mounted on a pin. These races occupy radial space that decreases the bending and shear strength of the gear and pin. The challenge has always been to design a gear and pin with sections that are as small as possible to reduce cost, and as large as necessary to maintain structural performance, and as large as necessary to provide enough space for bearings. Planet-Pac eliminates this design dilemma by combining the inner races with the planetary pin and the outer races with the planetary gear. An optimized Planet-Pac extracts its advantage by allowing the designer to use thicker gear sections in smaller diameter gears while at the same time, creating more radial space for larger diameter rolling elements that add to bearing capacity and bearing L-10. Studies show that increasing the ratio of rim thickness to gear module, decreasing pin



Planet carrier equipped with tapered roller bearing

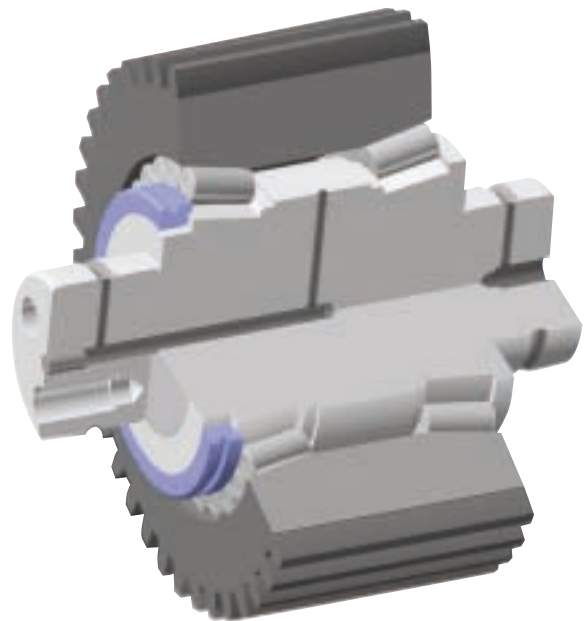

Planet Pac uses a full roller complement tapered roller bearing construction where bearing preload can control gear contacts

INTEGRATED FLEXPIN BEARING FOR SINGLE WALLED PLANETARY CARRIERS

High performance epicyclical gearing systems inherently place more stress on all the components. Gear stresses are elevated from load and misalignments created by the torsional wind up of the planetary carrier. The designer might try to solve the stress problem by increasing gear face length and using lead correction and gear profiling to manage the stress along the gear tooth. A logical approach would be to decrease unit load by increasing the number of planets to more than 3, but then it becomes less certain what percentage of the power is being transmitted through each mesh. All of these challenges can be resolved by applying one simple product.

The Timken Integrated Flexpin Bearing (IFB) is built around the principle of a double-cantilever shaft that extends from a single walled planetary carrier. This construction provides circumferential compliancy among planets to insure uniform load distribution among the planets (testing shows K-gamma for 7 planets is close to unity at all load levels). Just as important, the single walled carrier construction virtually eliminates gear tilting from torsional wind up. This means, unit loading on the gears and bearings is decreased by virtue of using more planets and improving K-gamma, and misalignment from torsional wind up is virtually eliminated.

Additionally, the IFB construction

is based on full integration of bearing races with the planet gear and sleeve, allowing radial space for the bearing rolling elements. Bearings may also be very precisely preloaded at the bearing factory so that the spring rate of each IFB remains constant permitting uniform loading among planets. The IFB represents state-of-the-art technology in epicyclical gearing system design. Its compliant construction offers the greatest opportunity for reducing gear mass and balancing reliability of all system components.



Advantages of Flexpin:

- Flexibility permits the application of more planets to reduce unit gear contact load
- Increase reliability through lower, more predictable gear contact and improved contact pattern
- Single-wall carrier reduces axial dimension and weight of the epicyclical gearing system
- Short assembly times (ready to mount product)

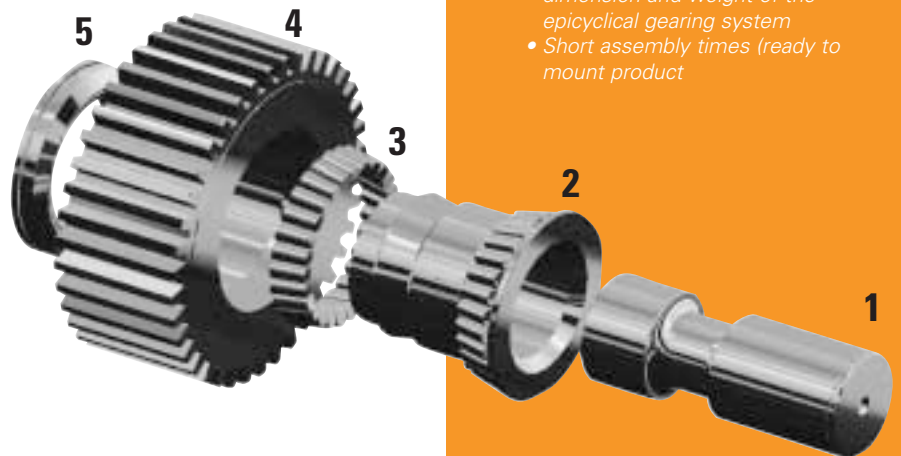

Flexpin:
made of only 5 types of pieces:
1 - pin
2 - cones/sleeve
3 - rollers
4 - cup/gear
5 - adjustable rib

TIMKEN PRODUCT RANGE FOR THE GEAR DRIVE INDUSTRY

STANDARD BEARINGS (METRIC AND INCH)

- Tapered roller bearings
- Spherical roller bearings
- Cylindrical roller bearings
- Needle bearings

CUSTOMIZED APPLICATION BEARINGS (METRIC AND INCH)

- Tapered roller bearings
- Spherical roller bearings
- Cylindrical roller bearings
- Needle bearings

SPECIAL BEARING PROGRAMS

- Duraspexx Power Rating Series
- P900
- Thin section tapered roller bearings

ENGINEERED SOLUTIONS

- Engineered surfaces
- Application engineering support

SERVICES

- Bearing repair
- Bearing installation and maintenance training
- Service engineering

POWER RATING SERIES

For heavy-load applications like gear drives, Timken offers a line of high-performance tapered roller bearings that have been specially designed to last longer than traditional bearings.

The Duraspexx Power Rating Series can enhance reliability, reduce downtime and yield two times catalog life, based upon a 23 percent rating increase over traditional Timken bearings. Simply put, the Duraspexx Power Rating Series allows you to pack more power into an existing envelope.

This power density principle can result in countless cost-saving advantages. You can downsize the bearings, shaft, gears, housing and other related components, enjoying the benefits of a lower system cost while handling the same loads.

Or, you can increase horsepower and achieve higher torque without the costly process of retooling the entire system.

Delivered with standard lead times, the Duraspexx Power Rating Series is available in a wide range of sizes from an established list of part numbers.



TIMKEN ENGINEERED SURFACES

Timken has developed a host of engineered surface technologies that enhances a gear's load carrying capabilities and overall performance. The coating can be used on all industrial gear drives.

By integrating Timken engineered surfaces into a design, value is added to new higher rated gearboxes that deliver either more torque or more power through an existing system. The net result is better gears and better shafts with a more efficient, higher performance design.

Whether it is a helical, spur, bevel or worm gear, the Timken engineered surfaces team works with customers to integrate a toolbox of technologies that maximize the performance of their products. Depending on the coating, Timken engineered surfaces can increase a gear's scuffing and pitting resistance by more than 30%. The gear's torque capacity increases drastically or the pitting and scuffing life extends significantly.

Timken offers four different surface treatments for various purposes:



Planetary sun gear untreated on the top and with ES treatment on the bottom



Spherical roller bearing with ES treatment

ES10/20

Topographical modification process: provides some wear and friction reduction in poor lubrication.

ES30

Topographical modification process: provides some wear and friction reduction in poor lubrication, and increases fatigue life.

ES200

Moderately hard coating with low friction: provides superior scuffing and fretting protection to sliding contacts, and fatigue-life enhancement to rolling contacts.

ES300

Hard coating with reduced friction: provides limited scuffing protection, abrasion resistance and superior fatigue-life enhancement to rolling contacts.

A PARTNER IN DEVELOPMENT

Timken works closely in development partnerships with its gear drive customers and continues to improve product efficiency, quality and reliability through a mutual exchange of industry experience with these partners.

We advise not only on bearing selection and correct fitting practices, but also offer proprietary calculation tools for analyzing the bearing technology of the machine design.

Our engineers use a powerful analytical software tool developed by Timken, to predict application performance for the bearings, the gears, the shafts and the housing.

A team of Timken sales and application engineers works continually with customers to ensure that our products meet their needs.

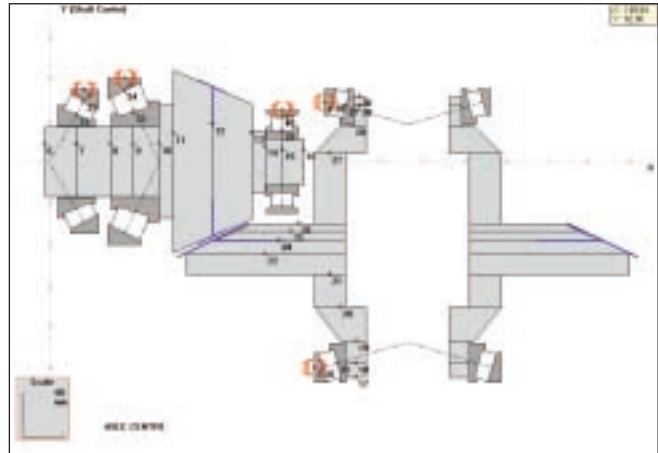

A mesh view

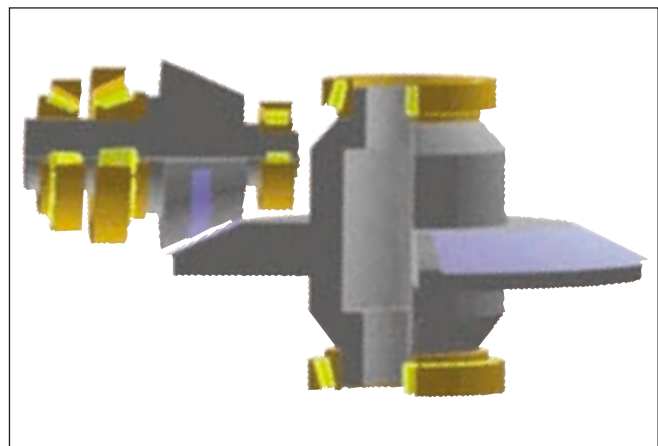

A solid view

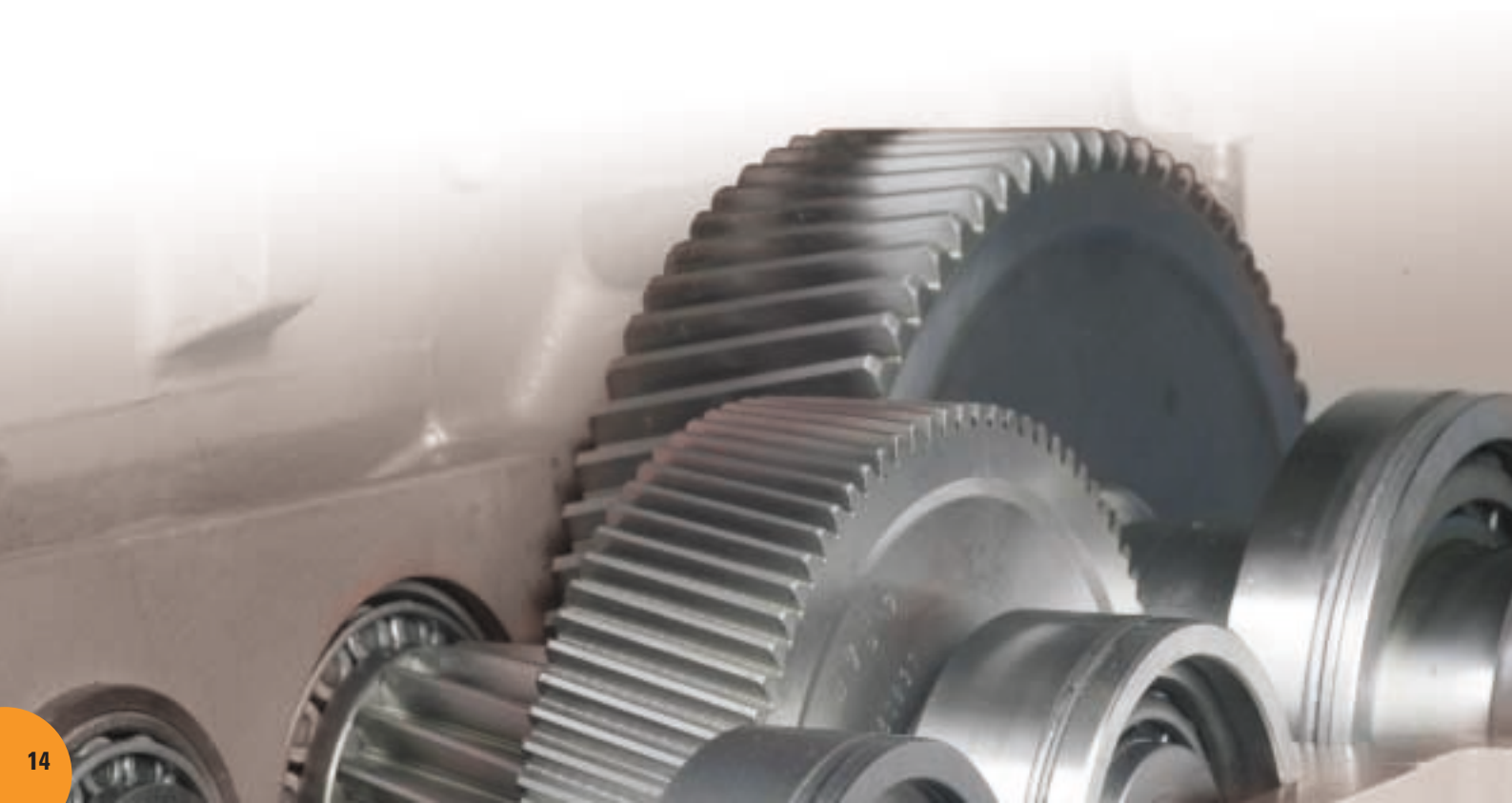

REDUCING DEVELOPMENT LEAD TIMES

Our software tools provide engineers with the information needed to make critical design and performance decisions early in the development cycle. This can reduce development lead times by identifying potential problems before physical testing begins.

The power of the software lies in the fact that all Timken analytical models have been gathered in a single tool, and that these models have been validated versus experimental results. The package is also extremely user friendly with an impressive list of graphical input/output features.

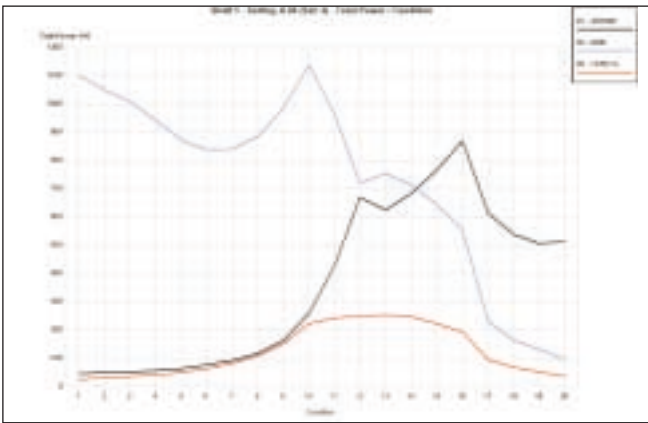

More than 100 graphs can be plotted as a function of the load cycle or as a function of the setting condition. The graphs allow the application engineer to focus directly on the most critical conditions in a cycle using the life depletion graph. All the bearing performance criteria, can be analyzed through the cycle using one graph.

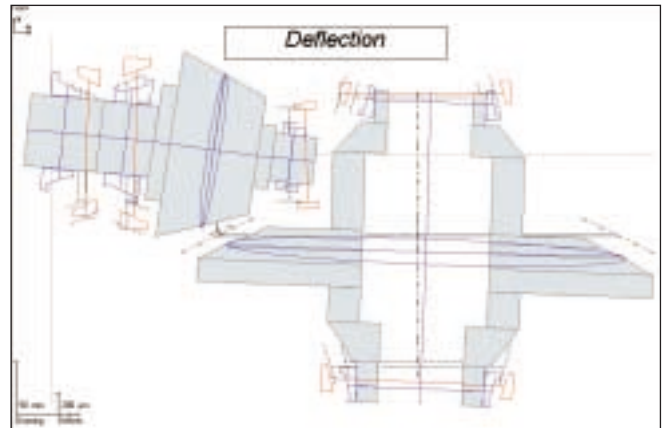
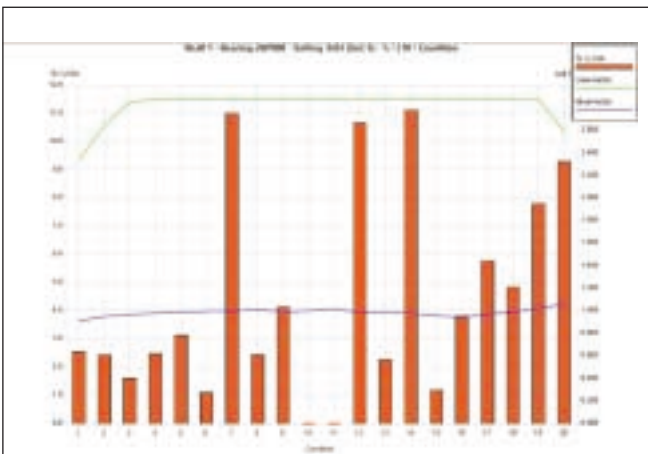

The deflection of the shafts is visually displayed, as well as the relative bearing race and gear displacement. These deflection plots can be obtained in different views, in order to have a better understanding of the relative movements.

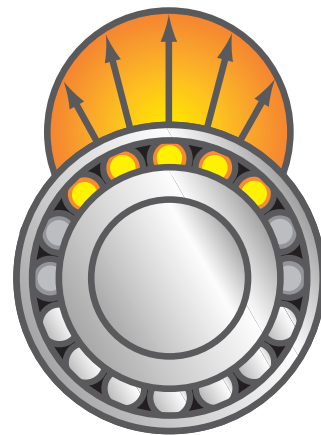

For each bearing, the load distribution, forces and displacements are shown in bearing section. The roller-race pressure distribution on the most loaded roller can also be displayed. Roller-rib contact dimension and stress can be visualized as well.

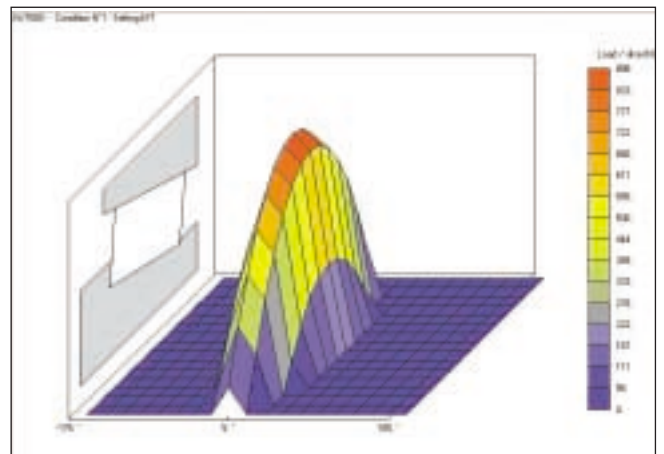

For more information contact your
local sales engineer or visit us at:

www.timken.com

Less Friction. More **Solutions**

Timken does more than just sell bearings.

Please talk to us about:

- technical services
- power density
- gear surface treatment
- integrated flexible pin bearings
- condition monitoring.

Timken® is the registered trademark of
The Timken Company.
www.timken.com

TIMKEN

©2005 The Timken Company
Printed in Europe