

TIMKEN
Where You Turn

Reliable Solutions For Aggregate

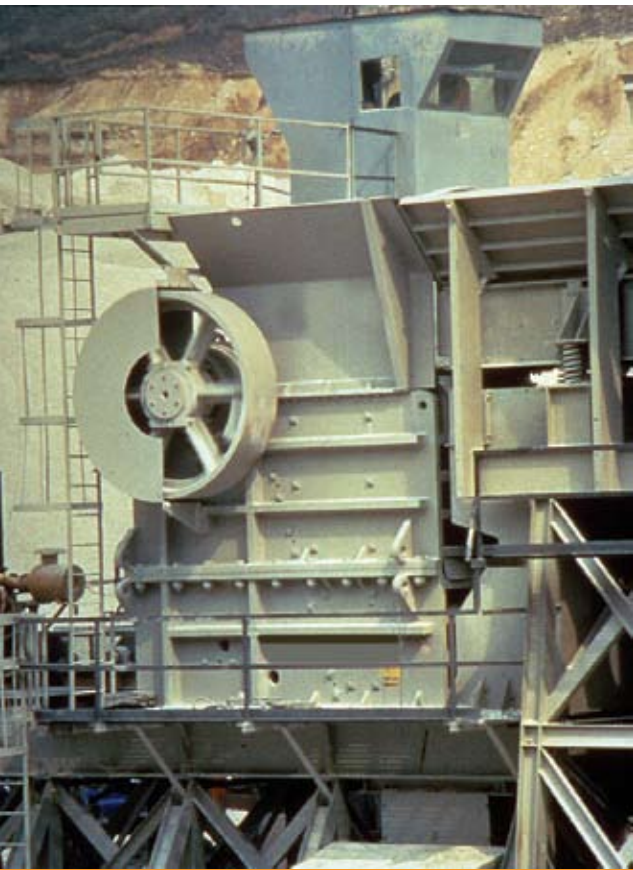





Our engineers are committed to understanding your processes to solve your application problems. We partner with your maintenance teams to optimize bearing performance in standard products. This spirit of collaboration also is used to develop customized bearing solutions unique to your applications.

For more than 50 years, Timken has provided a full product line for the aggregate industry. During this time, we have developed and prototyped products to meet the industry's changing requirements. This expertise allows Timken to offer a broad range of friction management solutions to help keep aggregate plants running at maximum efficiency.

Comprehensive, Reliable Solutions For Aggregate

Global customers recognize Timken for the quality and durability of aggregate products that include the Timken, Torrington and Fafnir brands. Timken's product portfolio includes seals, condition monitoring, maintenance

tools, greases and single point lubricators. Our expanded services include training seminars, bearing remanufacture, application-specific engineering and reliability services.



Features

- High-quality steel
- Enhanced roller surface finishes
- Enhanced race surface finishes
- High-strength brass material
- Centrifugally cast, fully-machined YM or YMB cage

Benefits

- Improved roller stability provided by cage wrap
- Optimized roller end geometry improves roller guidance
- Enhanced cage design provides lower running temperatures

Our standard bearing material minimizes the impact of debris in harsh environments like those found in the aggregate industry.

Timken’s Spherical Roller Bearings For Aggregate: Better By Design

Timken® spherical roller bearings are ideally suited for aggregate applications because they are manufactured from the finest quality steels using the highest quality standards. Our standard bearing material minimizes the impact of debris in harsh environments, like

those found in the aggregate industry. At the core of the design, Timken offers a fully machined brass cage. The benefits of the brass cage are numerous, including greater durability and cooler operation. New surface finishing techniques on the roller and raceway surfaces further enhance these benefits.



Timken understands that vibrating screens are one of the most demanding applications for anti-friction bearings. Timken’s Technology Center uses an in-house testing facility to further understand how operating conditions in a vibrating screen affect bearing performance.

Timken uses this first-hand knowledge to develop enhancements in our vibrating screen bearings. When compared to other global brands, Timken spherical roller bearings run cooler than the competition. A lower operating temperature extends bearing life by reducing friction, torque, heat generation and power absorption.

Bearing Operating Temperature Comparison

Timken design has lowest actual average bearing operating temperature.

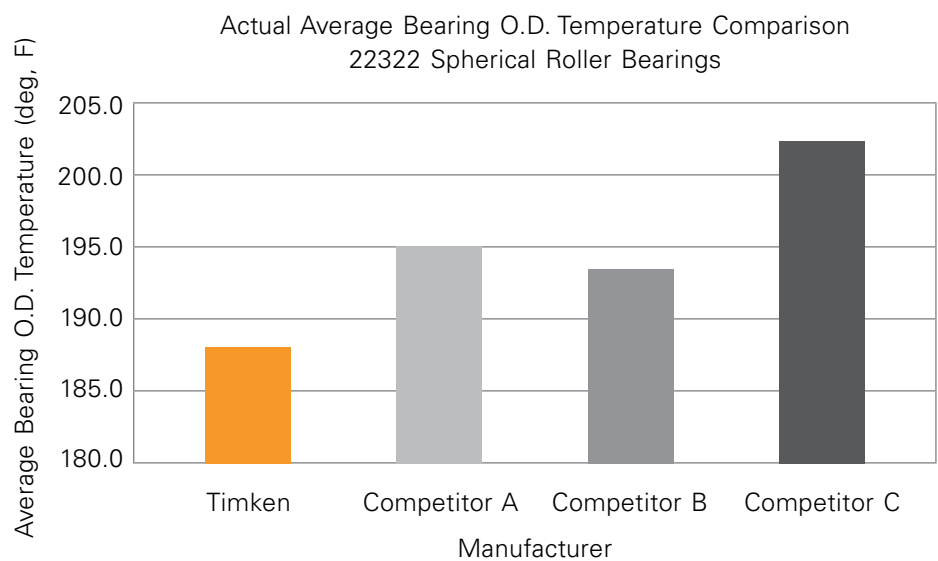

Jaw Crushers

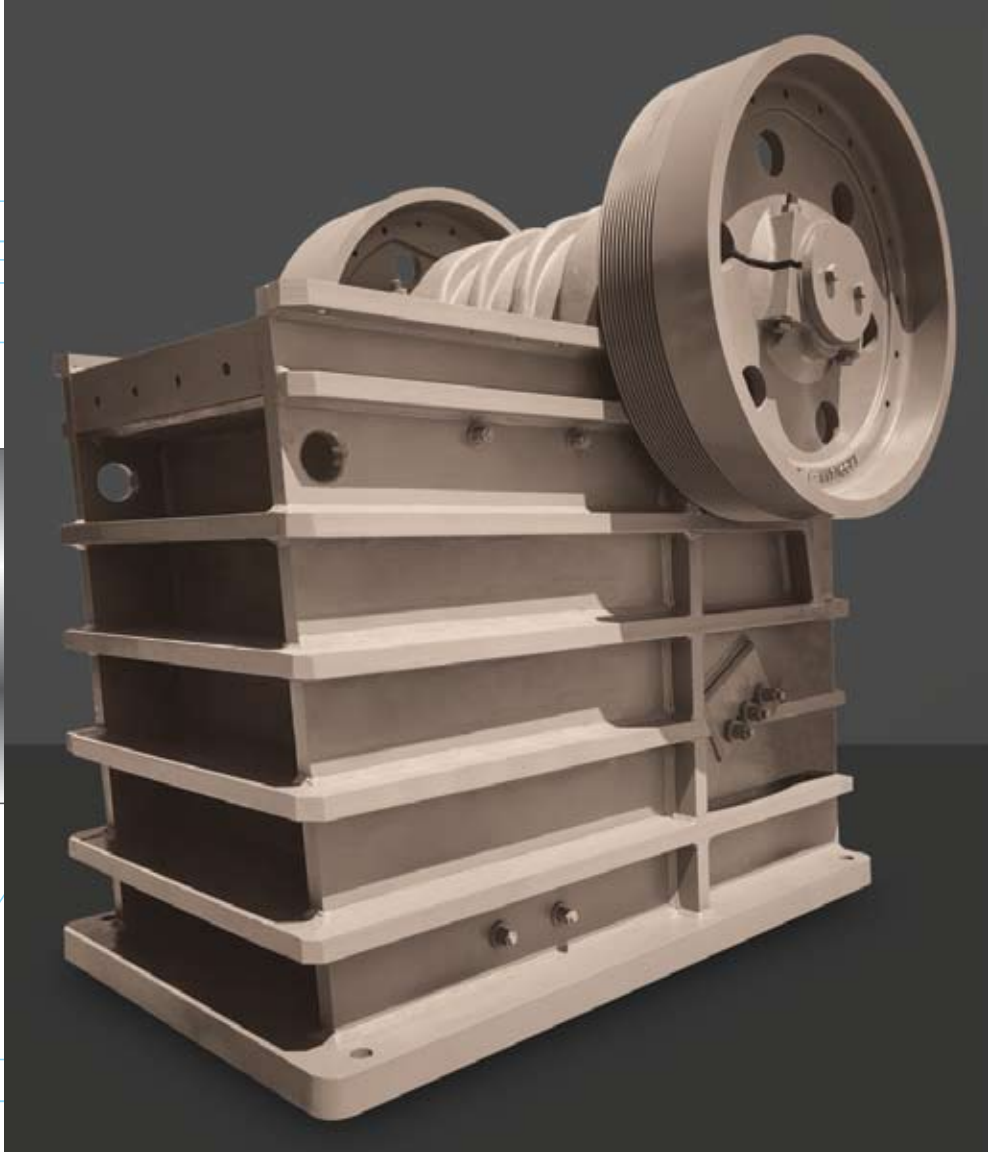
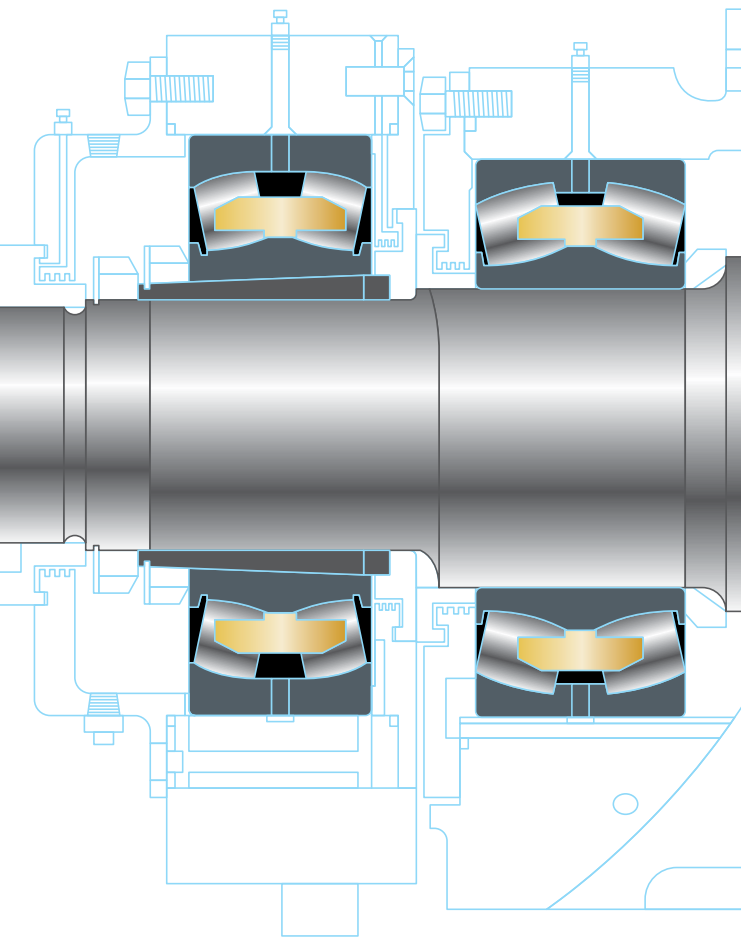

Adapter sleeves



Hydraulic nuts

The Jaw Crusher Challenge

Jaw crushers represent a considerable challenge to bearing performance. While speeds and loads are generally moderate, there are occasions when the load spikes as uncrushable material passes through the chamber. The contaminated environments in which jaw crushers typically operate are a constant threat to bearing life.

The Jaw Crusher Solution

Timken suggests our rugged YM and YMB spherical roller bearings. They feature heavy-duty machined brass cages designed to withstand challenging conditions like shock loading. Our robust spherical roller bearings are available with either a straight or tapered bore. Mounting these bearings is simple with Timken's full line of quality adapter sleeves, accessories and hydraulic nuts.



Impact-type Crushers

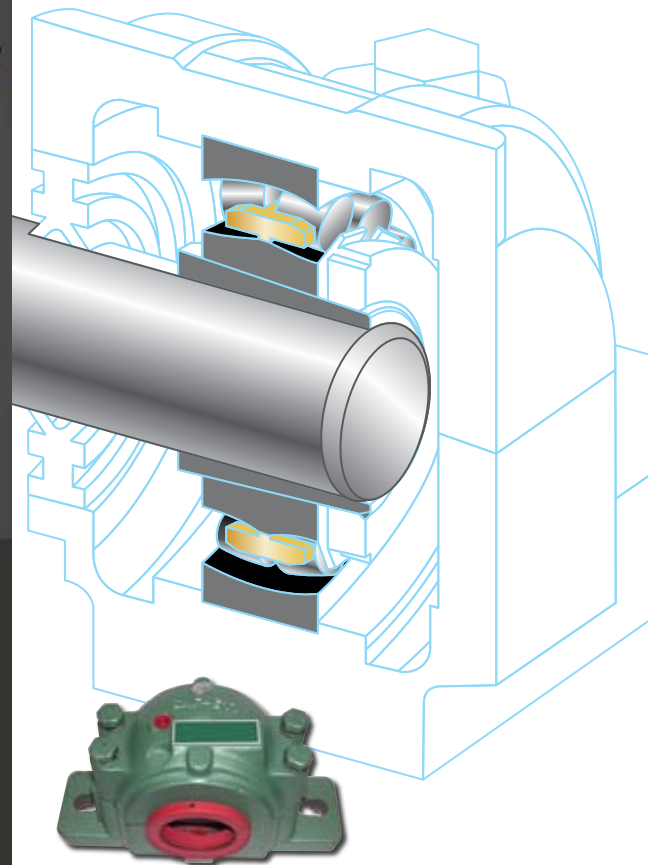

Heavy-duty pillow block

The Impactor Challenge

Vertical and horizontal impactors represent unique bearing conditions in the contaminated aggregate environment. Typical impactor designs use spherical roller bearings for flexibility in design and to accommodate misalignment. However, other bearing types can be used that endure high rotational speeds and variable loading. Maintaining low bearing temperature and providing adequate lubrication are critical.

The Impactor Solution

Timken engineers specify heavy-duty pillow blocks constructed with either cast iron or cast steel material for impactors. These pillow blocks combat uplift loads caused by impact, vibration, jamming or stalling. They are also equipped to handle circulating oil systems that help maintain proper bearing operating temperatures and lubrication conditions.

Proper sealing is essential to prevent bearing contamination from abrasive material. Timken engineers typically recommend seal upgrades such as the Labyrinth or DUSTAC™. These seal upgrades are interchangeable with the standard LER seal, but provide improved debris exclusion.



Labyrinth seal



DUSTAC™ seal

Cone Crushers

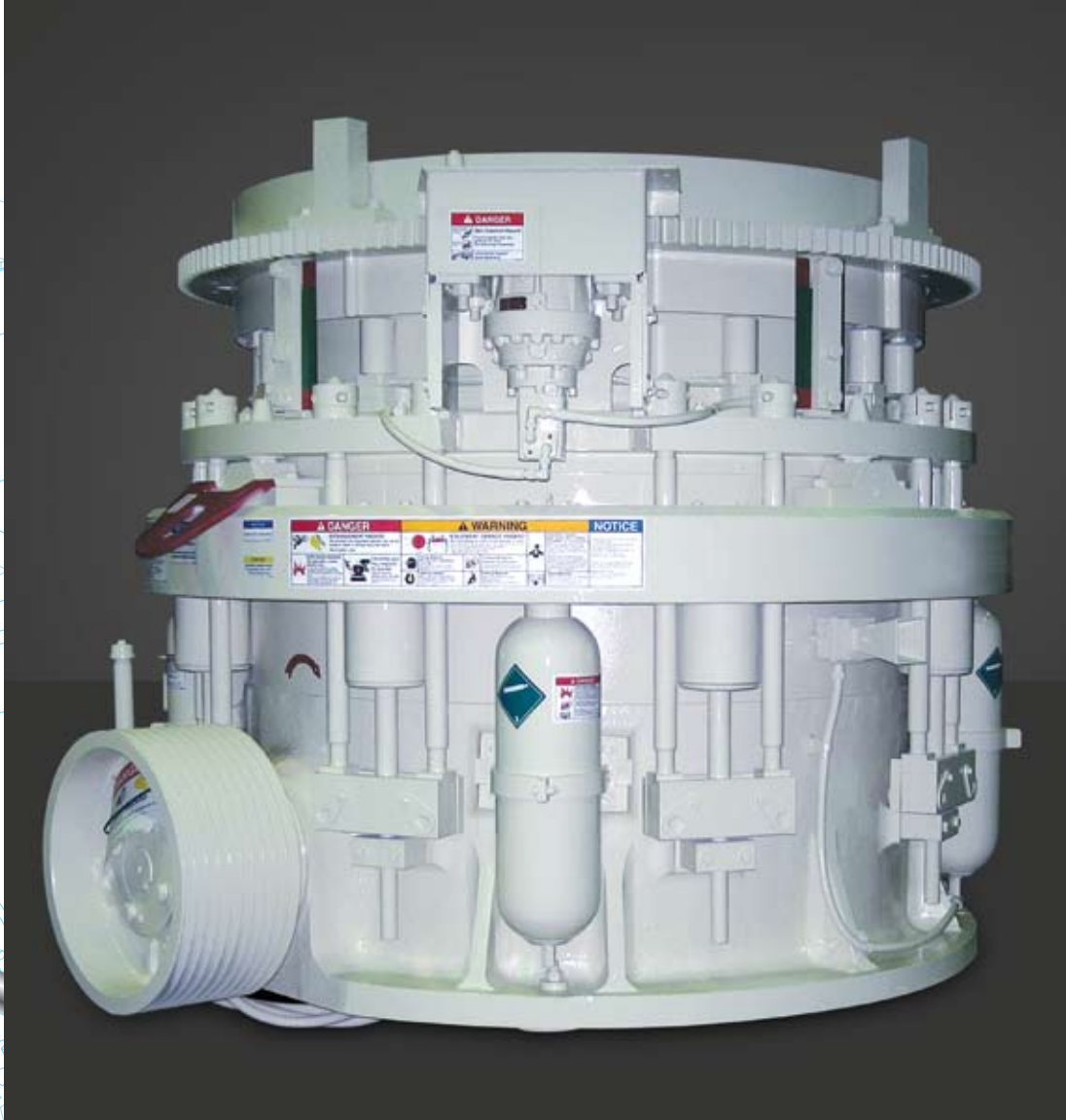
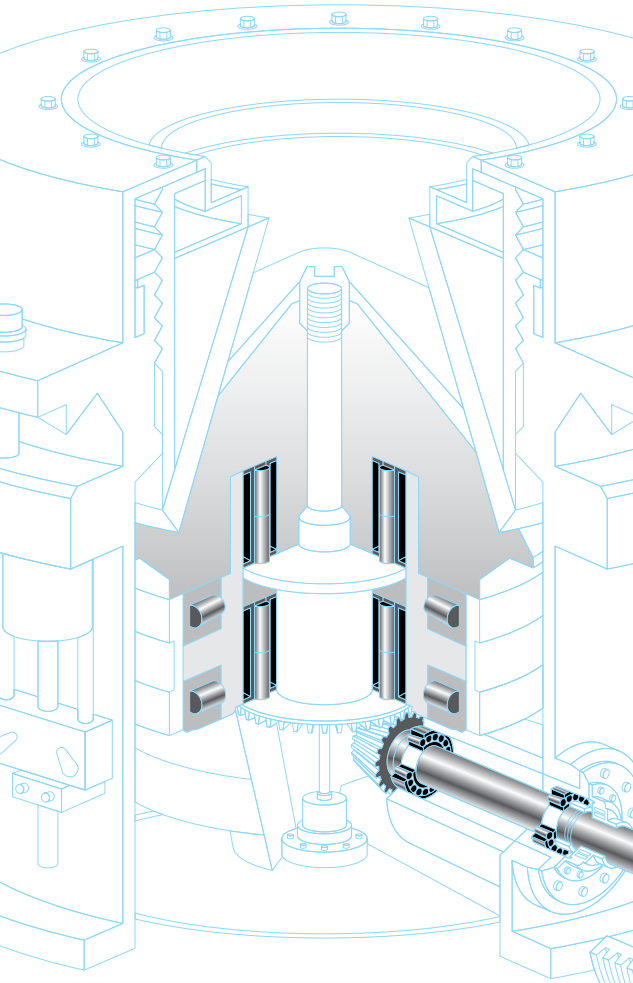

Timken bearings are engineered specifically for the conditions in a cone crusher.

The Cone Crusher Challenge

Cone crushers use a wide range of specialized bearings that are specifically designed for each model and the original equipment manufacturers' needs. These applications operate at moderate speeds under heavy loads. Because of the potential for severe shock loads, maximizing load-carrying capability is key.

The Cone Crusher Solution

Timken bearings are engineered specifically for the conditions in a cone crusher. Many designs use fully-machined brass cages for durability. If capacity requirements are extreme, other cage designs are used to optimize load-carrying capability when required. Timken controls key geometric features to provide trouble-free operation. We also offer a full line of bearings that provide excellent reliability for the input shaft.



Conveyors

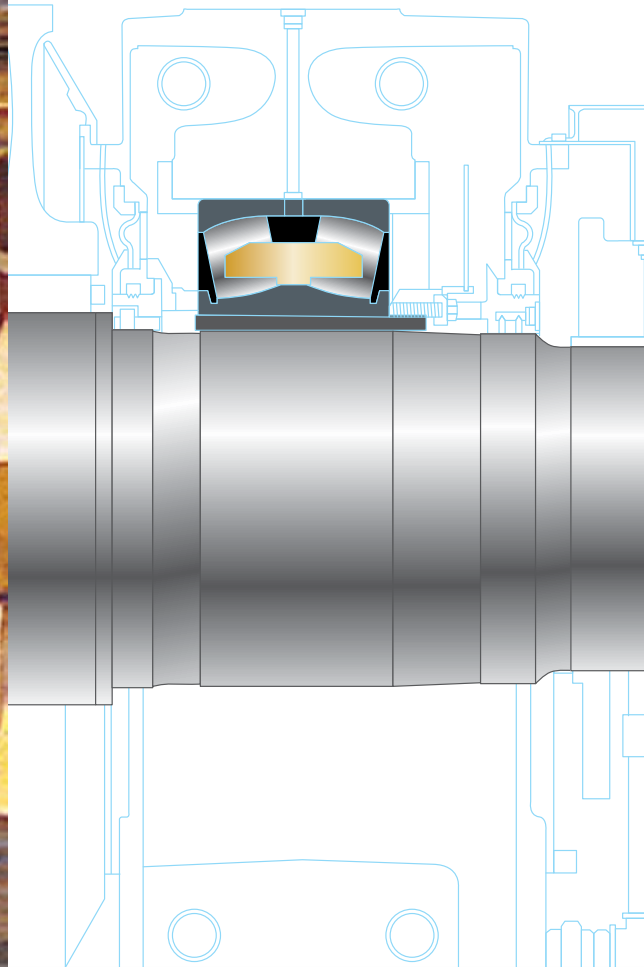

The Conveyor Challenge

Providing dependable operations in all possible conditions is the challenge of conveyor applications. The bearings selected for conveyors operate under moderate loads and speeds. However, the reliability of these bearings is key to the performance of the plant.

The Conveyor Solution

Timken engineers specify highly reliable products in key head and tail pulley positions. Depending on load and speed conditions, a spherical or a more cost-effective ball bearing housed unit can be selected. Since these conveyors also are exposed to extreme elements and contamination, sealing upgrades are available and suggested. One upgrade on ball-bearing housed units is the Fafnir Tri-Ply® seal which has been specially designed to perform well even in the most demanding conditions. To increase dependability, automatic lubrication systems can be programmed to supply grease.



Tri-Ply seal

Vibrating Screens

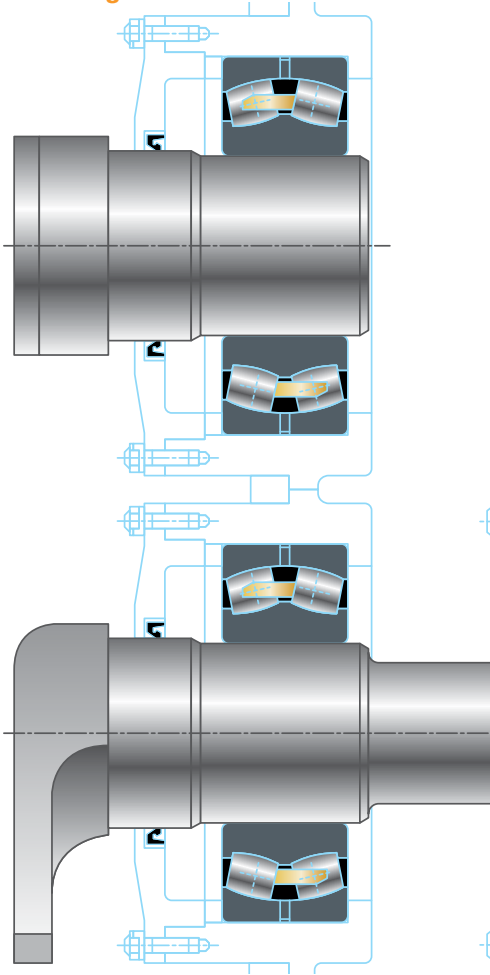

The Screen Challenge

Vibrating screens are one of the most demanding applications for antifriction roller bearings. Operating conditions result in high radial loads and high rotational speeds. In addition, screens generate high vibration on the bearing's cage and rollers, further increasing operating temperatures. Complicating this situation, screens operate in a wide range of environmental conditions, including extreme temperatures and severe contamination.

The Screen Solution

Timken offers a complete line of spherical roller bearings, including the 23 and 33 series. While the 23 series is more common, the 33 series bearings offer higher load capacity, as they maintain the same bearing bore and outside diameter. Key to the spherical roller bearing design is the one-piece fully machined brass cage. The cage pocket wraps around the roller, providing excellent roller guidance as the rollers rotate in and out of the load zone. The roller end and cage pockets are specifically designed to promote lubrication flow and reduce operating temperatures.

Timken also offers a line of cylindrical roller bearings (CRB) with a rugged one-piece machined brass cage, designed for the unique conditions in vibrating screens. CRBs provide increased load-carrying capacity and lower temperature generation than traditional spherical roller bearing designs. Additionally, CRBs can have specially designed roller profiles to minimize stress across the roller contact and provide optimal performance.

Vibrating Screens

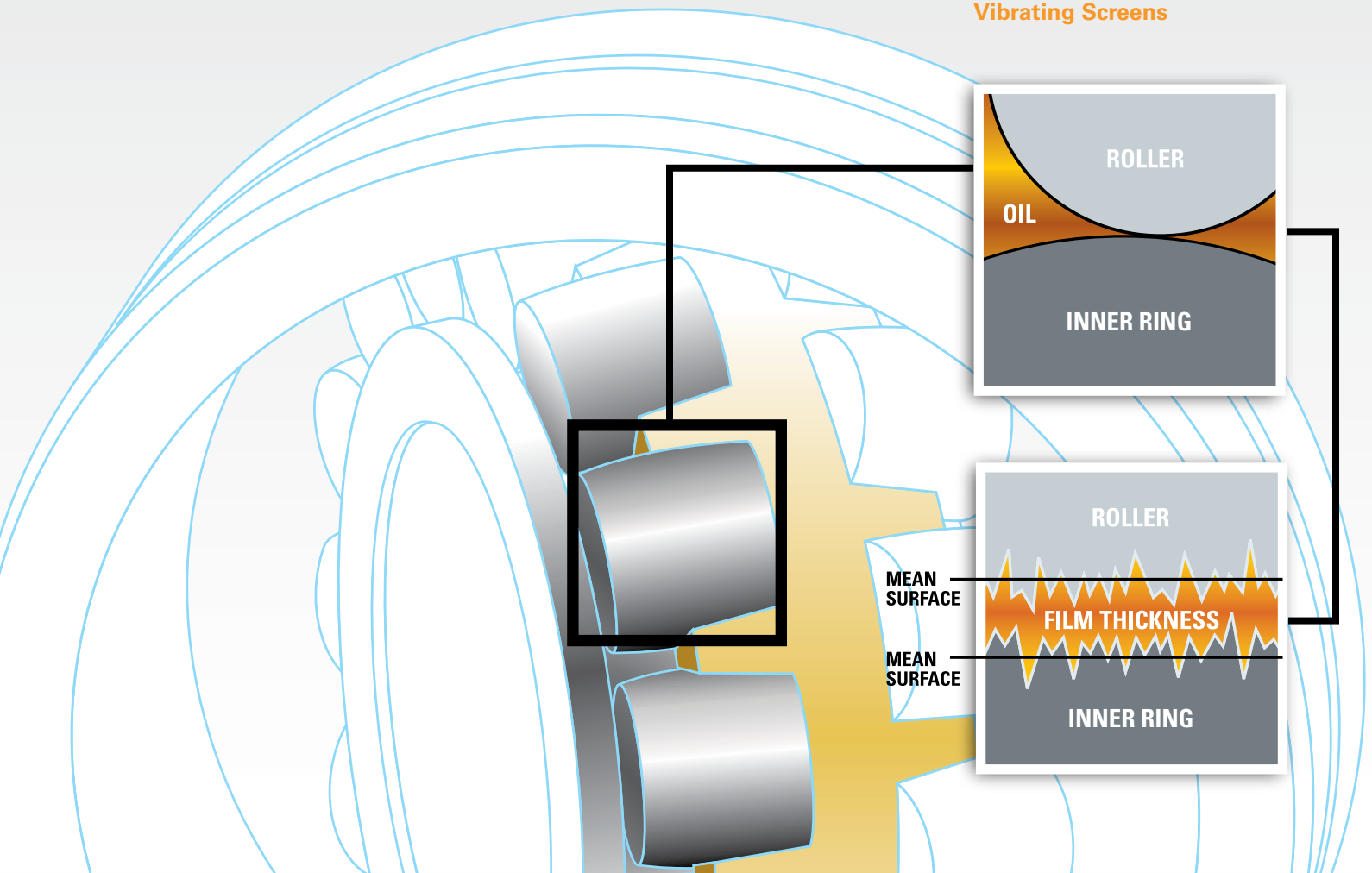

Lubrication

A bearing lubricant must perform three basic functions:

- Reduce friction and wear by separating adjacent surfaces and limiting metal-to-metal contact.
- Transfer heat from the bearing surfaces.
- Protect the bearing surfaces from corrosion and dirt contamination.

For satisfactory bearing performance, proper lubrication and generated film thickness is essential in the raceway and roller-end contacts.

The success of a vibrating screen is dependent on adequate bearing life. Problems with improper lubrication and/or abrasive wear often reduce the life of screen

bearings. Therefore, selecting the proper lubricant and lubrication system are key to successfully operating a vibrating screen.

For both grease and oil systems, the viscosity of the base oil is one of the most important considerations in selecting the proper lubricant.

Due to the operating conditions of a vibrating screen, most screen bearings have to perform under high operating temperatures. The load zone of the bearing can be 30°F (17°C) higher than the sump temperature and 40°F (22°C) higher than the housing temperature. The bearing operating temperature is critical because it affects lubricant viscosity

and lubricant life. As a general rule, a lubricant should maintain a minimum viscosity of 105 SUS (21.8 cSt) at the bearing operating temperature for adequate lubrication. With the improved analytical tools that exist today, Timken's engineers are able to suggest the required viscosity based on the load, speed and temperature conditions of a particular screen.

The most common types of lubrication systems used by vibrating screen manufacturers are manual grease, automatic grease feed, oil splash and circulating oil systems. Oil mist and drip feed systems have also been used, but to a lesser extent.

Grease Systems

Manufacturers often use grease lubrication systems because it simplifies sealing and is an economical choice. In addition, the grease acts as an extra barrier against contamination. However, grease is not suitable for all applications because it cannot operate at higher speeds.

Grease consists of a base oil, a thickener and assorted additives. The important grease properties are the thickener type, the viscosity of the base oil, the consistency of the grease, and the mechanical and chemical stability. Typically, mineral oil based greases are used in vibratory applications. However, synthetic grease may be necessary if operating at elevated temperatures, for example 200-250°F (90°C-120°C).

For most vibrating screen applications, NLGI grade 2 greases with extreme pressure (EP) and anti-corrosive additives are suggested. At higher ambient temperatures, a higher NLGI grade grease may be required. A higher NLGI grade grease may also be necessary for labyrinth seals to help improve sealing, but it must be compatible with the bearing grease.

When initially filling a bearing with lubricant, enough grease should be added to lubricate the bearing contact surface and exclude contamination. However, care should be taken not to over-grease the bearing, as that can lead to excessive heat generation from lubricant churning. For vibrating mechanisms, the suggested initial fill quantity is 30 to 50 percent of the free volume in the bearing and

30 to 50 percent of the free space in the housing. The free volume in the bearing can be estimated by:

$$V_{\text{free}} = \frac{\pi}{4} (D^2 - d^2) (C) - \frac{W}{\rho_{\text{steel}}}$$

Where:

V_{free} = free volume in the bearing (in³, cm³)

D = bearing outer diameter (in, cm)

d = bearing bore (in, cm)

C = bearing width (in, cm)

W = bearing assembly weight (lb, kg)

ρ_{steel} = average steel density (0.283 lb/in³, 7.8x10⁻³ kg/cm³)

To determine the corresponding mass of grease, the percentage of the bearing void volume to be filled is multiplied by the density of the grease. An approximate density of 0.032 lb/in³ (0.90 g/cm³) can be used if the exact grease density is not known.

Bearings need to be regreased when grease leaks through seals, breaks down due to high operating temperatures or shearing, or when it is contaminated. Determining the proper regreasing amount and frequency is difficult because it is application specific. It depends on factors such as the bearing speed, the type and grade of grease, the effectiveness of the seals, the operating temperature and the environment. Grease should be

Selecting the proper lubricant and lubrication system is key to successfully operating a vibrating screen.

Mixing greases should be avoided because different types of thickeners are not always compatible.

purged before it exhibits thickening, separation of oil, acid formation, or a noticeable degree of hardening. The relubrication intervals must be more frequent if there is significant abrasive contamination. The regreasing cycle is typically determined by original equipment manufacturers, based on past experience. Relubrication should be performed via the lubrication groove and holes in the outer diameter of the bearing.

Mixing greases should be avoided because different types of thickeners are not always compatible. If attempting to mix greases, consult your lubricant supplier first.

Oil Systems

Oil lubrication systems dissipate heat faster and allow bearings to operate at higher speeds than grease systems. Another benefit of oil systems is the ability to add a filtration system to remove contamination during operation.

Oil lubrication can be accomplished by several methods, with splash and circulating oil being the most common in vibrating screens. Splash oil systems can be used at moderately high speeds, if properly designed with a large oil reservoir and a large cooling surface. The housing design can have a major influence on the degree of cooling provided. In high-speed and high-load applications where the heat generated cannot be dissipated by a splash system, circulating oil systems are used. Circulating oil provides a continuous, regulated oil flow that improves heat removal and washes away contamination from the bearing. Heat exchangers can be included in

a circulating oil system to reduce oil temperature and extend lubricant life. Filters also can be used with the system to remove debris that could potentially cause bearing wear.

There are many additives available to enhance the properties of oils. Similar to grease, EP and anti-corrosive additives are suggested for oil used in vibrating screens. For applications with high operating temperatures or more demanding conditions, synthetic oils can be used.

The oil viscosity required to generate the proper film thickness during operation depends on the bearing load, speed, and operating temperature. Oils with an ISO 150 or 220 grade are commonly used in vibrating mechanisms. For exact viscosity requirements for a specific application, contact your local Timken sales engineer for a detailed lubrication analysis.

The life of an oil depends on its oxidation stability and operating temperature. The change in appearance of the lubricant should be used as a guideline for replacing it. Oil should be changed more frequently if significant abrasive contamination is present. OEM recommendations for oil-change frequency should be followed.

For a comprehensive lubrication analysis, contact your local Timken sales engineer.



With the improved analytical tools that exist today, Timken's engineers are able to suggest the required lubricant viscosity based on the operating conditions of a particular screen.

Vibrating Screens

Maintaining proper fitting practice is key to extending bearing life and preventing shaft and housing damage.

Spherical Roller Bearings - Internal Clearance

Radial internal clearance before installation – Bearings with cylindrical bore

Bore Diameter (mm)		Radial Internal Clearance (mm) (in)		Bore Diameter (mm)		Radial Internal Clearance (mm) (in)	
		C4				C4	
Over	Incl.	MIN.	MAX.	Over	Incl.	MIN.	MAX.
30	40	0.060	0.080	100	120	0.160	0.210
		0.0024	0.0031			0.0063	0.0083
40	50	0.075	0.100	120	140	0.190	0.240
		0.0030	0.0039			0.0075	0.0094
50	65	0.090	0.120	140	160	0.220	0.280
		0.0035	0.0047			0.0087	0.0110
65	80	0.110	0.145	160	180	0.240	0.310
		0.0043	0.0057			0.0094	0.0122
80	100	0.135	0.180	180	200	0.260	0.340
		0.0053	0.0071			0.0102	0.0134

Note: C4 Clearance is most common in bearings used in vibrating equipment

Typical Vibrating Screen Bearing Modifications For Spherical Roller Bearings

- W20 = Outer ring with standard lube holes
- W22 = Outer ring with reduced O.D. tolerance
- W33 = Outer ring with standard lubrication holes and machined lubrication groove in center of O.D. This feature is standard unless otherwise specified.
- W40I = Inner ring made of carburizing grade steel
- W47 = Inner ring with oversized bore
- W49 = Outer ring with oversized OD
- W50 = Tapped holes in face of inner ring
- W64I = Inner ring only made of premium quality carburizing grade steel
- W88 = Inner ring with reduced bore tolerance
- W98 = Inner ring with undersized bore
- W800 = Combines W88 and W22 features and the upper 2/3 of the specified clearance
- W810 = Combines W33, W50, W98 and W22

Standard screen bearings are:

- 223XX YM W33 W800 C4
- 233XX YM W33 W800 C4
- YM = One-piece roller riding machined bronze cage
- YMB = One-piece land riding machined bronze cage

Suggested Fitting Practice For Spherical Roller Bearings In Vibrating Screens

The typical suggested fitting practice for vibrating screen bearings is a loose shaft fit and a tight housing fit. The exception to this practice is for the main bearing of a single-shaft, four-bearing mechanism, in which the suggested fitting practice is a tight shaft fit and a loose housing fit.

For a detailed analysis and advice on fitting practices, contact your local Timken representative.

Single-shaft, two-bearing mechanism
s4 shaft fit (loose)
P6 housing fit (tight)

Double-shaft, four-bearing mechanism
s4 shaft fit (loose)
P6 housing fit (tight)

Single-shaft, four-bearing mechanism

Main Bearing

m6 shaft fit (tight)
H7 housing fit (loose)

Eccentric Bearing

s4 shaft fit (loose)
P6 housing fit (tight)

Note: The s4 fit designation as referenced on this page is a special fit tolerance developed by The Timken Company for this specific application. It DOES NOT conform to ISO standards similarly published as s4 preferred shaft fits.

Suggested Fitting Practice For Vibrating Screens

Bearing Number		Nominal Dimensions						Shaft O.D. s4 Fit		Housing Bore P6 Fit		Shaft O.D. m6 Fit		Housing Bore H7 Fit	
Series		Bore		O.D.		Width		MAX. (mm)	MAX. (in)	MAX. (mm)	MAX. (in)	MAX. (mm)	MAX. (in)	MAX. (mm)	MAX. (in)
23	33	mm.	in.	mm.	in.	mm.	in.	MIN. (mm)	MIN. (in)	MIN. (mm)	MIN. (in)	MIN. (mm)	MIN. (in)	MIN. (mm)	MIN. (in)
22308		40	1.5748	90	3.5433	33	1.2992	39.977	1.5739	89.970	3.5421	40.025	1.5758	90.035	3.5447
								39.967	1.5735	89.948	3.5413	40.009	1.5752	90.000	3.5433
22309		45	1.7717	100	3.937	36	1.4173	44.978	1.7708	99.970	3.9358	45.025	1.7727	100.035	3.9384
								44.968	1.7704	99.948	3.9350	45.009	1.7721	100.000	3.9370
22310		50	1.9685	110	4.3307	40	1.5748	49.977	1.9676	109.970	4.3295	50.025	1.9695	110.035	4.3321
								49.967	1.9672	109.948	4.3287	50.009	1.9689	110.000	4.3307
22311		55	2.1654	120	4.7244	43	1.6929	54.975	2.1644	119.970	4.7232	55.030	2.1666	120.035	4.7258
								54.964	2.1640	119.948	4.7224	55.011	2.1658	120.000	4.7244
22312		60	2.3622	130	5.1181	46	1.811	59.975	2.3612	129.964	5.1167	60.030	2.3634	130.040	5.1197
								59.964	2.3608	129.939	5.1157	60.011	2.3626	130.000	5.1181
22313		65	2.5591	140	5.5118	48	1.8898	64.975	2.5581	139.964	5.5104	65.030	2.5603	140.040	5.5134
								64.964	2.5577	139.939	5.5094	65.011	2.5595	140.000	5.5118
22314		70	2.7559	150	5.9055	51	2.0079	69.975	2.7549	149.964	5.9041	70.030	2.7571	150.040	5.9071
								69.964	2.7545	149.939	5.9031	70.011	2.7563	150.000	5.9055
22315		75	2.9528	160	6.2992	55	2.1654	74.975	2.9518	159.964	6.2978	75.030	2.9540	160.040	6.3008
								74.964	2.9514	159.939	6.2968	75.011	2.9532	160.000	6.2992
22316		80	3.1496	170	6.6929	58	2.2835	79.975	3.1486	169.964	6.6915	80.030	3.1508	170.040	6.6945
								79.964	3.1482	169.939	6.6905	80.011	3.1500	170.000	6.6929
22317		85	3.3465	180	7.0866	60	2.3622	84.967	3.3452	179.964	7.0852	85.035	3.3479	180.040	7.0882
								84.957	3.3448	179.939	7.0842	85.013	3.3470	180.000	7.0866
22318		90	3.5433	190	7.4803	64	2.5197	89.967	3.5420	189.959	7.4787	90.035	3.5447	190.046	7.4821
	23318	90	3.5433	190	7.4803	73	2.874	89.957	3.5416	189.930	7.4775	90.013	3.5438	190.000	7.4803
22319		95	3.7402	200	7.874	67	2.6378	94.967	3.7389	199.959	7.8724	95.035	3.7416	200.046	7.8758
								94.957	3.7385	199.930	7.8712	95.013	3.7407	200.000	7.8740
22320		100	3.937	215	8.4646	73	2.874	99.967	3.9357	214.959	8.4630	100.035	3.9384	215.046	8.4664
								99.957	3.9353	214.930	8.4618	100.013	3.9375	215.000	8.4646
22322		110	4.3307	240	9.4488	80	3.1496	109.967	4.3294	239.959	9.4472	110.035	4.3321	240.046	9.4506
	23322	110	4.3307	240	9.4488	92.1	3.626	109.957	4.3290	239.930	9.4460	110.013	4.3312	240.000	9.4488
22324		120	4.7244	260	10.2362	86	3.3858	119.967	4.7231	259.953	10.2343	120.035	4.7258	260.052	10.2382
	23324	120	4.7244	260	10.2362	106	4.1732	119.957	4.7227	259.921	10.2331	120.013	4.7249	260.000	10.2362
22326		130	5.1181	280	11.0236	93	3.6614	129.959	5.1165	279.953	11.0217	130.040	5.1197	280.052	11.0256
	23326	130	5.1181	280	11.0236	112	4.4094	129.947	5.1160	279.921	11.0205	130.015	5.1187	280.000	11.0236
22328		140	5.5118	300	11.811	102	4.0157	139.959	5.5102	299.953	11.8091	140.040	5.5134	300.052	11.8130
	23328	140	5.5118	300	11.811	118	4.6457	139.947	5.5097	299.921	11.8079	140.015	5.5124	300.000	11.8110
22330		150	5.9055	320	12.5984	108	4.252	149.959	5.9039	319.949	12.5964	150.040	5.9071	320.057	12.6006
	23330	150	5.9055	320	12.5984	128	5.0394	149.947	5.9034	319.913	12.5950	150.015	5.9061	320.000	12.5984
22332		160	6.2992	340	13.3858	114	4.4882	159.959	6.2976	339.949	13.3838	160.040	6.3008	340.057	13.3880
	23332	160	6.2992	340	13.3858	136	5.3543	159.947	6.2971	339.913	13.3824	160.015	6.2998	340.000	13.3858
22334		170	6.6929	360	14.1732	120	4.7244	169.959	6.6913	359.949	14.1712	170.040	6.6945	360.057	14.1754
								169.947	6.6908	359.913	14.1698	170.015	6.6935	360.000	14.1732
22336		180	7.0866	380	14.9606	126	4.9606	179.959	7.0850	379.949	14.9586	180.040	7.0882	380.057	14.9628
								179.947	7.0845	379.913	14.9572	180.015	7.0872	380.000	14.9606
22338		190	7.4803	400	15.748	132	5.1969	189.952	7.4784	399.949	15.7460	190.046	7.4821	400.057	15.7502
	23338	190	7.4803	400	15.748	155	6.1024	189.936	7.4778	399.913	15.7446	190.017	7.4810	400.000	15.7480
22340		200	7.874	420	16.5354	138	5.4331	199.952	7.8721	419.945	16.5332	200.046	7.8758	420.063	16.5379
	23340	200	7.874	420	16.5354	165	6.4961	199.936	7.8715	419.905	16.5317	200.017	7.8747	420.000	16.5354

NOTE: The 33 series bearings are approximately 15 to 20 percent wider than the 23 series and have approximately 15 to 22 percent more capacity. Many screens using the 23 series also can use the 33 series.

Vibrating Screens

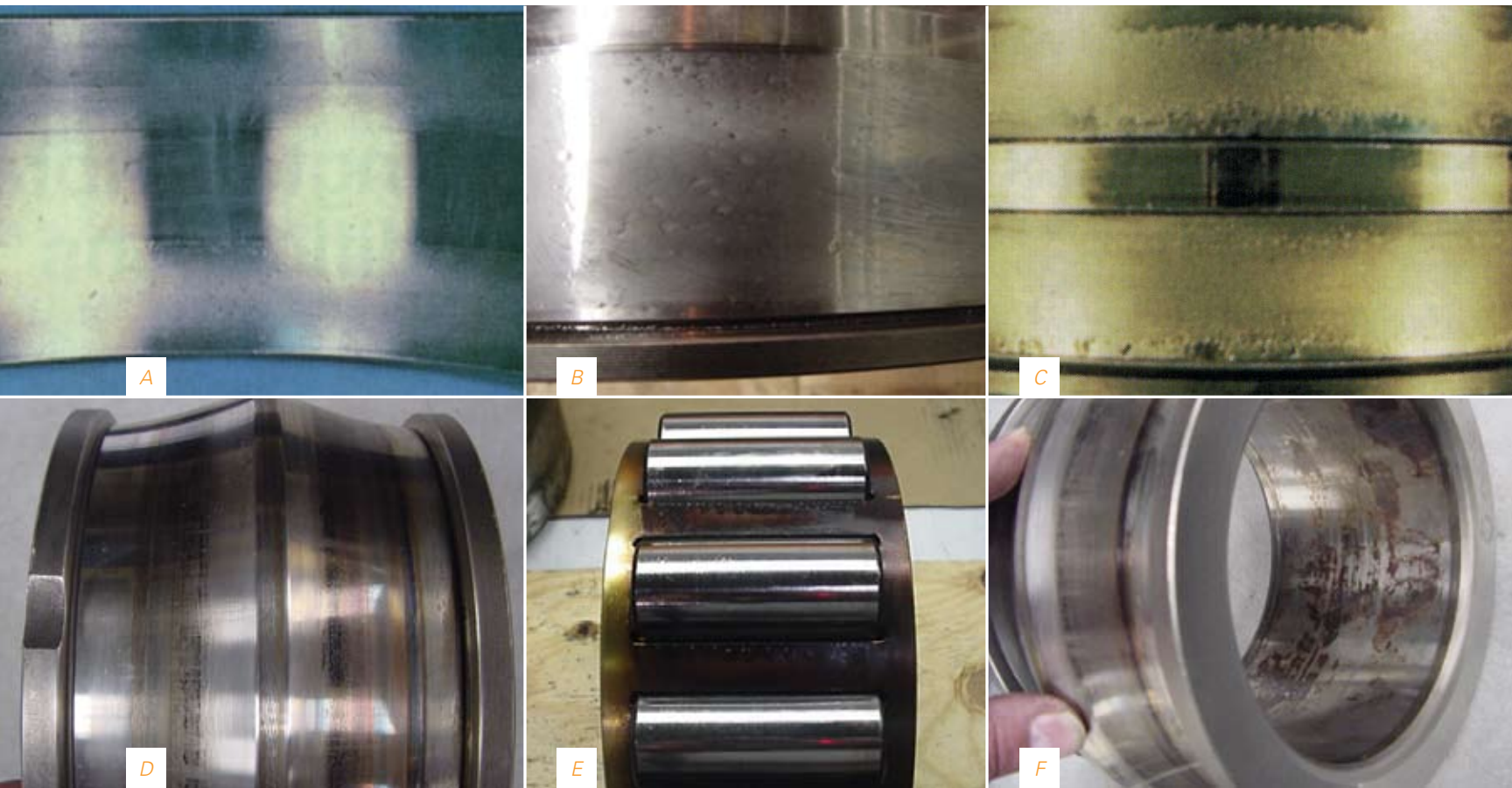

Bearing Damage Analysis

Abrasive Wear And Debris Denting

Abrasive wear and debris denting are two damage modes caused by contamination. They are two of the most common types of damage associated with vibrating screen bearings because of the environment in which they operate. Typical abrasive wear is frosty gray in appearance, as seen in picture A.

Debris particles also can dent the surface of the races and rollers as shown in picture B. This eventually leads to spalling damage. Frequent relubrication helps to purge contamination from the bearing. Persistent contamination problems could be a sign of improper sealing.

Inadequate Lubrication

Inadequate lubrication can be caused by improper lubricant viscosity, too little lubricant, too much lubricant or lubricant breakdown. Inadequate lubrication of screen bearings can result in fine grain spalling [picture C], heat damage [picture D] and oxidized lubricant staining [picture E]. See the Lubrication section for details on selecting the proper lubricant.

Fretting/Fretting Corrosion

Fretting or fretting corrosion normally affects the bore [picture F] or the outer diameter of a bearing. It typically results from a loose fit, leading to relative motion between the bearing and the shaft or housing. Corrosion that results from fretting should be removed from the bearing area because it is abrasive and will damage bearings and seals. Using the proper shaft and housing fits should minimize the amount of fretting damage to the bearing.

Common damage modes in vibrating screen bearings are related to contamination, improper lubrication and fretting.

Proper mounting is essential to ensure long bearing life.



A) Hydraulic pullers



B) Impact fitting tools



C) Induction heater

Maintenance Tools

Our line of maintenance tools is an example of how our friction management solutions extend beyond bearings. These value-added products are grounded in our knowledge of motion, lubrication, friction and metallurgy. They are designed to help you extend bearing life through proper installation, removal and service.

Pullers

Timken has a wide range of self-contained portable hydraulic pulling systems with capacities from four to 30 tons. They are excellent for the removal of many kinds of shaft-fitted parts.

Impact Tools

Proper mounting is essential to ensure long bearing life. Timken's impact fitting tool set features impact-resistant plastic collets, which help avoid metal-to-metal contact and the resulting damage that can occur. They are designed to permit safe, precise and quick mounting of bearings, bushings, sealing rings, cam wheels and pulleys.

When mounting spherical roller bearings and ball bearings in which the faces lie on the same plane, the collets enable load to be transmitted to the ring experiencing the interference fit. Mounting forces are not transmitted via the rolling elements and damage to the raceways is avoided.

Heaters

There are several ways to heat a bearing, but Timken suggests an induction heater with a thermostat. Induction heating is a superior, fast and controlled heating method. It is a safe and environmentally friendly alternative to traditional heating methods such as ovens, oil baths or blow torches.

Timken induction heaters can be used for gear wheels, bushings, couplings and other components. Proper mounting lengthens the lifespan of your equipment, and controlled induction heating helps prevent unnecessary damage.

Range Of Friction Management Solutions

Condition Monitoring

Timken's industrial portfolio of integrated services provides aggregate customers with ways to monitor and improve overall system performance. Our line of condition monitoring equipment evaluates the condition of a bearing, lubrication quality and machine vibration. The goal is to identify potential system issues before bearing damage occurs.

Industrial Seals

Timken's line of small-bore bonded industrial seals is made from innovative materials and processes that enhance life and performance in many industrial applications. The oil and grease seals feature precision sealing designs matched to many original equipment or aftermarket applications and help to ensure consistent and reliable performance.

The high-performance industrial seal line includes oil, split, lip, face-type and external seals in sizes up to 90 inches (2,300 mm). Timken also provides tools to ease installation, deter seal and bearing damage and prevent premature seal leakage.

Timken's line of seals offers a leading combination of quality, technology and coverage. These seals are developed using innovative material and process solutions to help protect machinery, prevent contamination and minimize plant downtime.

G-Power And M-Power Single-point And C-Power Centralized Multi-point Lubricators

Proper lubrication is critical to bearing and machine performance. To help prevent premature failures, Timken G-Power and M-Power single-point lubricators deliver periodic grease or oil to bearings, chains, guideways and other industrial equipment components. You can choose from gas-powered units or electromechanical varieties to meet your operating specifications.

C-Power multi-point lubricators are a centralized lubrication system capable of delivering grease to up to six lubrication points. Oil is not an option in this unit.

G-Power, M-Power and C-Power canisters can be filled with Timken-formulated lubricants or many other types of commercial lubricants. A full line of accessories – including brackets, clamps, brushes, fittings and hose extensions – ease installation and offer a host of mounting options for hard-to-reach locations.

Industrial Greases

Timken has a line of 10 application- and environment-specific grease lubricants. These lubricants were developed by leveraging our knowledge of tribology, anti-friction bearings, and how these two properties affect overall system performance. Our lubricants help bearings and related components operate effectively in demanding industrial applications.

Timken's construction and off-highway grease is suited for environments with extreme heat, heavy loads, high sliding wear, dirt, slow speeds and shock loading. Therefore, this grease is suitable for many applications within the aggregate industry.

Timken Construction And Off-highway Grease

- NLGI No. 2 grease
- Protects against rust and corrosion
- Excellent high-temperature properties
- Available in cartridges, pails, kegs and drums
- Operating temperatures of -40°F to 400°F (-40°C to 200°C)
- Provides resistance to extreme pressures caused by shock loading

Timken® Fafnir® Ball Bearing Housed Units

Timken offers a complete line of ball bearing housed units and replacement inserts. Both standard and flanged housed units are available in inch and metric shaft sizes. In addition to the standard offering, these units can be customized to meet specific applications. Fafnir® has continued to refine these products for more than 80 years, creating a proven product line.

Bearing Remanufacture

Timken's bearing remanufacture program helps customers save thousands of dollars in replacement costs for any bearing type and brand up to 84-inch (2,134 mm) outside diameters. Remanufactured bearings can be returned to their original specifications for less time and money than it takes to purchase new parts, without sacrificing performance.

Learn From The Leader

From mounting and advanced setting techniques to maintenance and damage analysis, Timken training seminars can provide practical hands-on knowledge and a comprehensive understanding of good maintenance practices.

Timken's comprehensive friction management solutions enhance performance, life and machine uptime.

Condition monitoring



Single-point lubricators



Housed units



Bearing remanufacture



Training



Industrial seals



Industrial greases

*Ethics and Integrity
Quality
Innovation
Independence*

TIMKEN
Where You Turn

The Timken Company

The Timken Company (NYSE: TKR, <http://www.timken.com>) keeps the world turning, with innovative friction management and power transmission products and services that enable customers to perform faster and more smoothly and efficiently. With sales of \$5.0 billion in 2006, operations in 26 countries and approximately 25,000 employees, Timken is Where You Turn™ for better performance.

To learn more about Timken's solutions for the aggregate industry, contact your local Timken representative or visit us at www.timken.com.

TIMKEN
Where You Turn

Bearings • Steel •
Precision Components • Lubrication •
Seals • Remanufacture and Repair •
Industrial Services

www.timken.com

Timken® is a registered trademark of
The Timken Company

© 2007 The Timken Company
Printed in U.S.A.
15M 05-07-29 Order No. 10136