

TIMKEN

Where You Turn

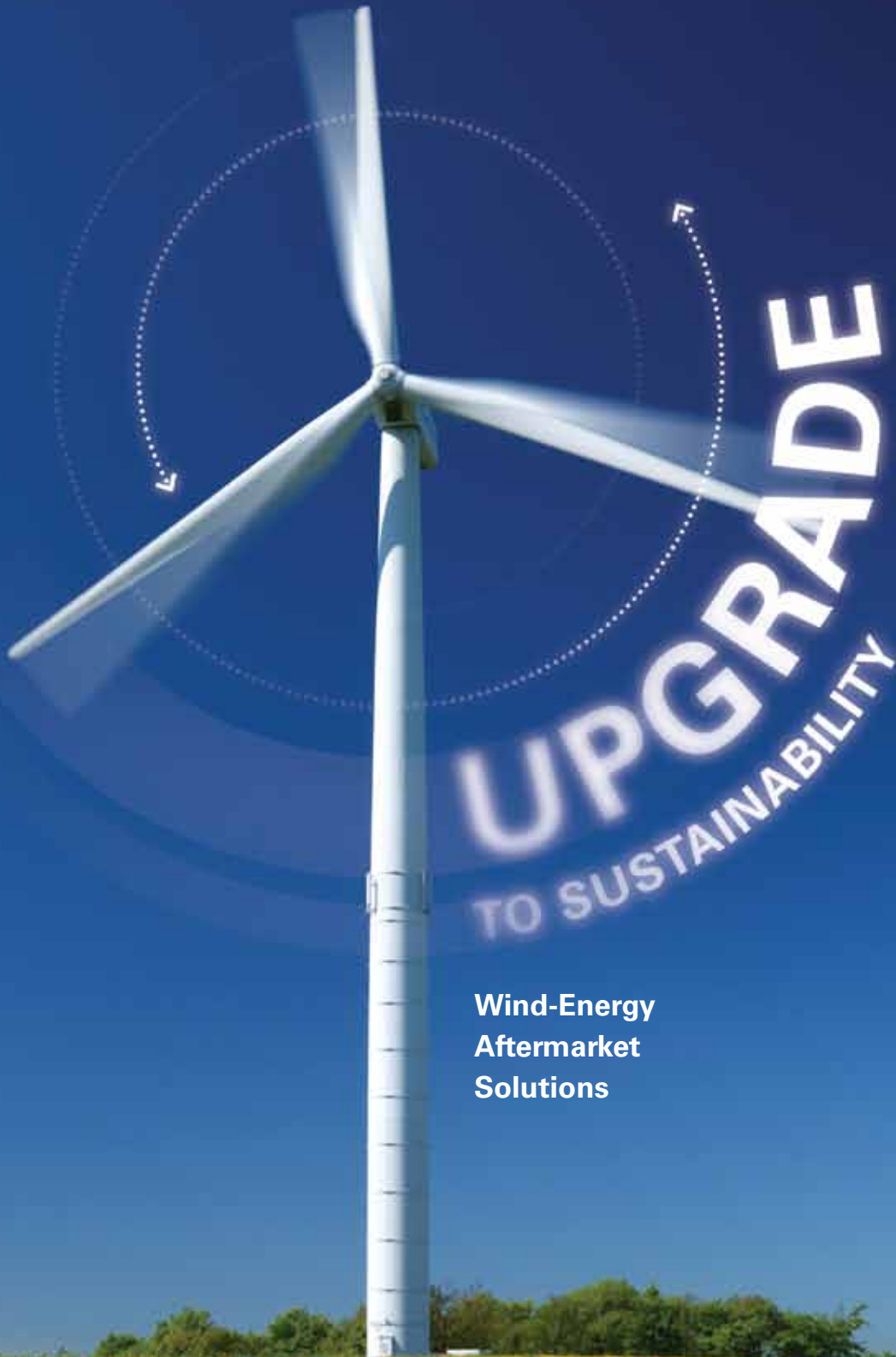

**Wind-Energy
Aftermarket
Solutions**

THE TIMKEN EXPERIENCE: QUALITY & PERFORMANCE ARE PRIORITIES

A Global Presence: Timken Wind-Energy Facilities Around the World

- ◆ Technology/Engineering Centers
- ◆ Repair Facilities
- ◆ Manufacturing Facilities



The Timken name stands for high quality, reliability and durability. Using our capabilities in bearing technology, manufacturing, application knowledge and engineering, we provide wind-turbine owners and operators with smart, cost-effective wind-energy solutions that help improve turbine performance, extend equipment life and lower total cost of ownership.

Wind turbines are expected to provide continuous performance despite extreme temperature fluctuations, variable winds, high loads and often in some of the most remote, hard to reach areas. That's why The Timken Experience provides a unique focus on:

- **Unparalleled engineering expertise** that helps enable our customers' equipment to run more efficiently, faster and longer with sustainability and superior performance.
- **Unique global network** provides on-site troubleshooting to identify bearing and shaft damage, determine root-cause problems and suggest a proper repair solution.
- **Lifecycle perspective** that provides a full range of support from replacement bearings and upgraded solutions to remanufacturing services, condition monitoring and lubrication systems.
- **Advanced solutions** for main-shaft and gearbox applications that are designed to operate under harsh conditions.
- **A total system approach** that addresses the complete wind turbine powertrain system, not just individual turbine components, and supports a variety of turbine configurations.

YOUR AFTERMARKET

SOLUTIONS PROVIDER

Unplanned wind-turbine downtime costs you money – as much as hundreds of thousands of dollars per incident. You need uninterrupted, dependable wind-turbine performance. But when your main-shaft and gearbox bearings fail prematurely, well short of their expected life, where can you turn? Timken offers a variety of upgraded, aftermarket solutions to help keep your main shafts and gearboxes running well.

PREDICTIVE MAINTENANCE PROGRAMS

Continuous, On-line Monitoring Systems

Predict unforeseen mechanical problems so you can get the most out of your equipment. Timken's On-line Intelligence System measures and analyzes vibration, shock pulses and a number of optional analog and digital inputs from geardrives and main-shaft bearings help to discover potential problems in the early stages to help you lower your total operating cost.

Portable Monitoring for Field Troubleshooting

A portable system that has all the same capabilities as our On-line Monitoring System but is packaged in a rugged, portable suitcase with external sensor connections. It is designed for field trouble shooting or temporary installations.

Bearing Fundamentals and Installation Training

Learn the basics of how bearings operate and what you need to do to help ensure maximum bearing life.

Up-Tower Inspections

When needed, Timken can provide skilled and certified technicians to perform up-tower inspections of main shaft, main-shaft housing and seals and counsel on proper bearing replacement and refurbishment.

REPAIR SERVICES

Main Shaft Repair and Reconditioning

Send your main-shaft assembly to Timken for a full refurbishment. Our services include disassembly, cleaning and inspection, including a report with recommended actions. Our capabilities include shaft/housing refurbishment and installation of our recommended bearing selection.

Bearing Repair

Offers the flexibility of repairing main-shaft and gearbox bearings for a fraction of the cost and often with quicker lead-times.

Bearing Installation Tools

Timken's EcoPower Induction Heater is designed to heat the work piece faster and more evenly in a controlled manner, utilizing fixed or flexible coil configurations. Bearing pullers, impact tools and other installation tools are also available.

BEARING UPGRADES

Timken® Wear-Resistant Bearings for Main Shafts and Gearboxes

Significantly reduce wear with Timken wear-resistant bearings. They can result in up to ten times more life under lubricant-interrupted conditions, 3.5 times more life in low lambda conditions, 15 percent less operating torque and two times more life under debris conditions. Wear-resistant bearings can help improve uptime and operational efficiencies and lower total operating and maintenance costs.

Bearing Design Upgrades

To help protect against brittle flaking/white etch cracking, Timken recommends case-carburized, wear-resistant cylindrical roller bearings and Timken® tapered roller bearings.

Material and Process Upgrades

Case-carburized cylindrical roller bearings help protect against brittle flaking/white etch cracking on high-speed and high-speed-intermediate gearbox positions.

SYSTEM UPGRADES

Timken® Wind-Energy Lubrication System

This economical system provides automatic lubricant delivery through a single divider block which displaces a fixed amount of lubricant to each lube point on the bearing assembly. Injected grease creates pressure in the system to force out old grease.

Wind-Energy Seals

A variety of sealing options to meet the demanding requirements of the main-shaft bearing; available in elastomer or polyurethane materials.

Wind-Energy Greases

Timken grease formulas help increase performance and bearing life in critical wind applications.

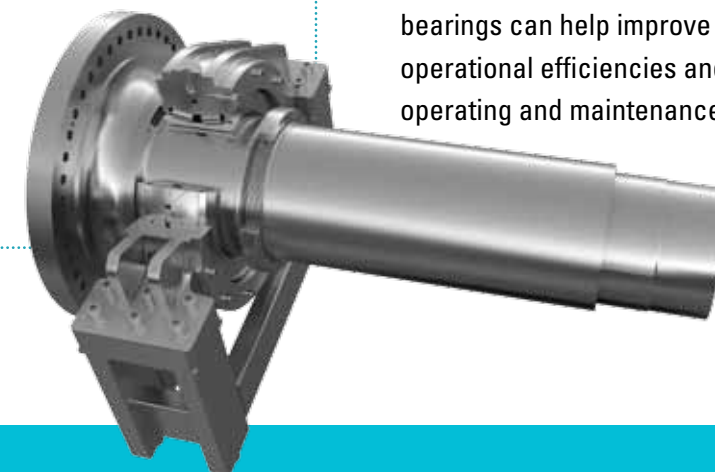

Life-Limiting Wear of a Single Main-Shaft Spherical Roller Bearing

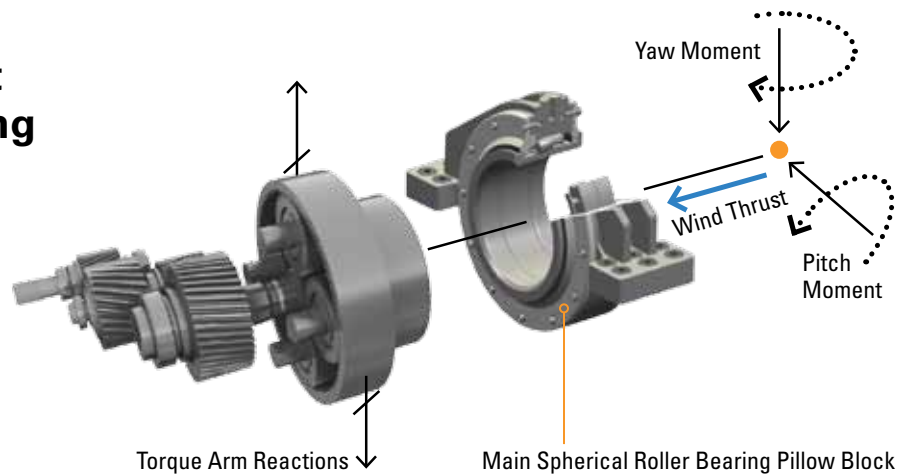
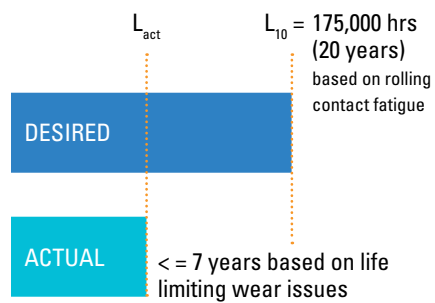

Conditions:

- Downwind row is more heavily loaded.
- Low speeds yield low lambda conditions.
- "Heathcoat slip" sliding with low lambda results in peeling/micropitting.
- Distinct wear path emerges in the center of the raceway.

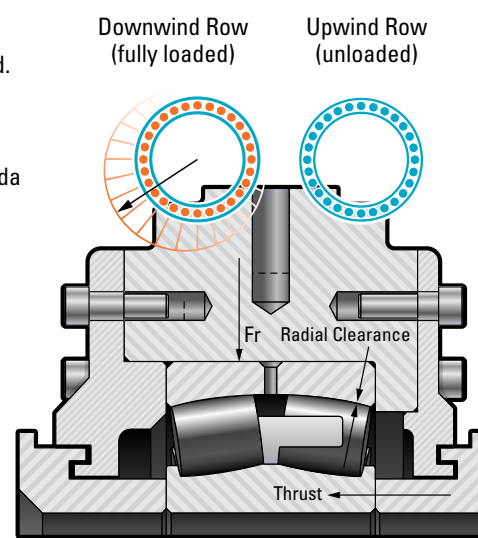

Reasons for Early Failure:

- As the micropitting continues, more and more material is worn away, leading to a loss of the design contact geometry in the center and increasingly higher stress concentrations at the edges of the wear track.
- The raceway spalling of these bearings is not because of classic surface-initiated or inclusion-related fatigue on which the predicted bearing life is calculated, but is due instead to the loss of the designed contact geometry due to micropitting wear.
- Bearing can show wear after five months, and may need to be replaced starting at five years of service.

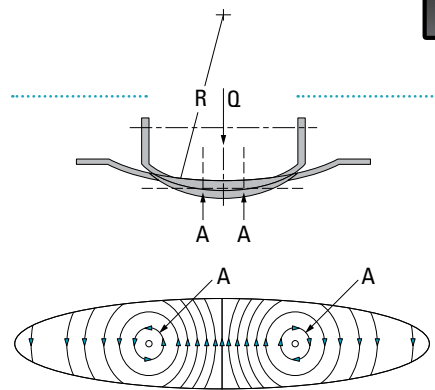

Variance and Surface Velocity Causes a Natural Sliding Between Roller and Raceway

Spherical roller bearing geometry dictates that there are at most two points of rolling contact (A). Differential or "Heathcoat slip" exists (pure sliding) at Q.

Look for the designation **240/600 YMDWE919** to help ensure your reliable solution.

A two-piece retainer design allows the upwind and downwind rows of a main-shaft spherical roller bearing to rotate independent of each other and reduce the magnitude of roller sliding on the raceways.

Wear-resistant bearing technology utilizes an engineered surface technology designed to protect raceways against micropitting wear by significantly reducing the shear stresses and asperity interactions in the contact.

TIMKEN SOLUTIONS TO COMMON BEARING FAILURES

For wind-turbine owners and operators, Timken wear-resistant and case-carburized bearings are the right choice for replacement bearings in main shafts and gearboxes.

Example	Failure Mode	Timken Solution/Benefit
	Brittle Flaking/ White Etch Cracking: Load reversals and rapid accelerations and decelerations of gearboxes create high loads on skidding rollers, causing near surface white etch areas that nucleate cracks. The cracks initiate at non-metallic inclusions and propagate toward the surface where a fracture can occur.	Wear-resistant bearings are designed to reduce shear stresses on raceways from skidding rollers. Case-carburized wear-resistant bearings help inhibit crack initiation and propagation.
	Debris/Contamination: Damage occurs on bearing raceways and rolling elements as debris trapped at the contact interface plastically deforms the steel, creating craters and raised edges. The raised edges cause high surface stresses that reduce bearing life.	Wear-resistant bearings polish away the raised edges around the debris craters, helping negate the fatigue-life-reducing mechanism.
	Micropitting: "Heathcoat slip" in spherical roller bearings operating in thin film lubrication causes cyclic shear stresses that initiate surface cracks and form micropits. Micropitting wear causes a loss of raceway profile geometry, and the resulting high stresses create fatigue.	Wear-resistant bearings help reduce the raceway shear stresses from "Heathcoat slip" that are responsible for micropitting wear.
	Smearing: Rapid accelerations and decelerations cause cylindrical rollers on the high-speed and high-speed-intermediate shaft bearings to skid, creating heat and adhesion between grinding asperities and a subsequent reduction of bearing fatigue life.	Wear-resistant bearings are designed to eliminate adhesion between the raceway and skidding roller; therefore reduce the risk of smearing wear.



TIMKEN

Where You Turn

Bearings • Steel •
Power Transmission Systems •
Precision Components • Seals •
Lubrication • Industrial Services •
Remanufacture and Repair

www.timken.com



2M 06-11:29 Order No. 10452

Timken® and Where You Turn® are registered trademarks of The Timken Company. • © 2011 The Timken Company • Printed in U.S.A.